

Order-No.: 5872 194 002

ZF – ERGOPOWER TRANSMISSION

4 WG-190/210

TECHNICAL DATA
DESCRIPTION
OPERATION
MAINTENANCE
DIAGNOSTIC SYSTEMS



ZF Passau GmbH
Donaustr. 25 - 71
D - 94034 Passau

Edition: 2001/08
Subject to changes w/o notice !



ERGOPOWER

Geschäftsbereich
Arbeitsmaschinen-Antriebe
und Achssysteme



2. Edition

Preface

The present Documentation has been developed for skilled personnel which has been trained by the ZF for the Maintenance and Repair operations on ZF-units.

However, because of technical development of the product, the Maintenance and Repair of the unit in your hands may require differing steps as well as also different setting and test data.

This Manual is based on the technical state at the printing.

At the preparation, every possible care has been taken to avoid errors.

However, we are not liable for possible mistakes concerning the representation and the description.

We are reserving ourselves the right of modifications without previous information.

The responsibility lies with the owner and the user, to pay attention to the safety indications, and to carry out the Maintenance operations according to the prescribed Specifications.

The ZF is not liable for faulty installation, incorrect treatment, insufficient Maintenance, improperly and unskilled performed works, and for the subsequential damages resulting from it.

It is ***imperative*** to pay attention to the corresponding Specifications and Manuals of the Vehicle Manufacturer.

Important Informations concerning the technical reliability and reliability in service are accentuated by the following Symbols:



Valid for Instructions which must be observed at the Maintenance, the Performance or the Operation of the vehicle !



Is inserted at working and operating procedures which have to be exactly respected to avoid a damage or destruction of the unit or to exclude a danger to persons !

TABLE OF CONTENTS

	Page:
Summary of the TECHNICAL DATA	6 - 7
IMPORTANT INSTRUCTIONS	9 - 10
<u>I. DESCRIPTION</u>	11
1.1 Function of the Converter	
1.2 Powershift transmission	
1.3 Transmission control	
1.4 Controllers	
1.4.1 General	
1.4.2 Controller DW-3	
1.4.3 Controller ERGO II	
1.5 Display	
1.5.1 General	
1.5.2 Possible Indications on the Display	
1.5.3 Error code definition	
1.6 Electronic control unit TCU	
1.7 Electronic control for the ZF-Powershift transmission	
1.7.1 General	
1.7.2 Description of the Basic functions	
1.7.3 AEB	
1.7.4 Downshifting functions (Down-Shift Button)	
1.7.5 Pressure cut-off	
1.7.6 Inching device	
1.7.7 Special functions	
<u>II. INSTALLATION SPECIFICATION</u>	25
<u>III. OPERATION</u>	27
3.1 Driving preparation and Maintenance	
3.2 Driving and Shifting	
3.3 Cold start	
3.4 Transmission control in the Driving range Automatic	
3.5 Stopping and Parking	
3.6 Towing	
3.7 Oil temperature	
<u>IV. MAINTENANCE</u>	31
4.1 Oil grade	
4.2 Oil level check replacement intervals	
4.3 Oil change and Filter replacement intervals	
4.3.1 Oil change and Oil filling capacity	
4.3.2 Filter replacement	
<u>V. DIAGNOSTIC SYSTEMS</u>	35
5.1 General	
5.2 MOBIDIG 2001	
5.3 Laptop Version	
5.4 Multi-System 5000	

ANNEX, comprising:

Tables:

- 1 Layout 4 WG-190/210**
- Installation view 4 WG-190/120**
- 2 Front view - Direct installation**
- 3 Front view - Separate mounting**
- 4 Rear view - Standard version**
- 5 Rear view - With disc brake**
- 6 Rear view - With 1. and 2. power take-off**
- 7 Schedule of measuring points and connections 4 WG-190/210**
- 8 Oil circuit diagram 4 WG-190/210 (Forward 1st speed)**
- 9 Electro- hydraulic control with proportional valves**
- 10 Power flow 4 WG-190/210 Forward/Reverse Speed**
- 11 4 WG-190/210 Fully automatic control EST-37
 Circuit diagram - 6029 717 040 –**
- 12 Controller DW-3**
- 13 Controller ERGO II**
- 14 Type plate**

Abbreviations used in the text:

Abbreviation	Description
EST-37	Ergocontrol
AEB	Automated determination of the filling parameters
TCU	Electronic control unit

TECHNICAL DATA

			WG-190	WG-210
Engine power:	max. KW*	190	210
Turbine moment:	max. Nm*	1 500	1 650
Engine speed:	max. min ⁻¹ *		2 600
Starting torque multiplication:			2,0 bis 3,0
Engine-dependent Power take-offs:				
	Torque:	Nm	800
	Speed:	n	1 x n _{Engine}
Mass (without oil):	kg about**		470

* = dependent on Vehicle type and application

** = dependent on the Transmission version

Description:

The ZF-Transmissions 4 WG-190/210 are composed of a hydrodynamic torque converter and a rear-mounted multi-speed powershift transmission with integrated transfer case (see Table- 1).

The torque converter is a wear-free starting device which is infinitely variable adapting itself to the required situations (necessary input torque).

Input by direct mounting via diaphragm on the engine, or separate installation (input via universal shaft) with DIN-, Mechanic- or Spicer-input flange.

The transmission can be shifted manually or fully-automatically by means of the Electronic unit EST-37.

Torque converter:

Unit size W 300 and 340 with torque multiplication.

Powershift transmission:

4 Forward speeds and 3 Reverse speeds.

Output:

The powershift transmission has between input and output shaft a center distance of 540 mm, and can be equipped with the following components:

- with output flanges to the front and rear axle for different universal shafts
- on the rear output (rear-side) with a disk brake as parking brake
- on the converter side with axle disconnection.

Power take-off:

For the drive of an external oil pressure pump, an engine-dependent, coaxial power take-off is planned.

It allows the attachment of pumps with „SAE-B and C“ Connection.

If desired engine dependent power take-off are available also up to 2.

Transmission accessories:

Upon request, the transmissions can be additionally equipped with the following components:

- Emergency steering pump with a feed rate of 16 cm³/rev. or 32 cm³/rev.
- Electronic speedometer signal, here the Electronic unit EST-37 offers a speedometer signal.

Transmission ratio (mechanical)*

SPEED	DRIVING DIRECTION	Ratio 4 WG-190/210
1	Forward	3,632
2	Forward	2,089
3	Forward	1,072
4	Forward	0,636
1	Reverse	3,444
2	Reverse	1,981
3	Reverse	1,017

* = According to the Transmission version, other ratios are also possible.



IMPORTANT INSTRUCTIONS

Oil level check (see 4.2):

In the cold start phase, the engine must be running about 2 – 3 minutes at idling speed and the marking on the oil dipstick must then be lying above the cold start mark. The oil level check in the transmission must be carried out at engine idling speed and operating temperature of the transmission (80° to 90° C).

At stationary engine, the oil level in the transmission is rising essentially, according to the installation conditions !

At every oil change, the ZF-Fine filter must be exchanged. In addition, ZF recommends to start the autonomous calibration of the shifting elements (AEB).

The independent calibration of the shifting elements (AEB) must be started after the initial installation of the transmission and the Electronics in the vehicle at the Vehicle Manufacturer and after every replacement of the transmission, the electrohydraulic control or the TCU in case of a failure.

Put the Controller at the starting of the engine always to the Neutral position. At running engine and transmission in Neutral, the parking brake must be engaged or the service brake be actuated, to prevent the vehicle from rolling.

Prior to every start off, loosen the parking brake.

The engagement of the speed out of Neutral is only possible under the programmed transmission input speed (turbine speed).

Neutral position of the selector switch at higher vehicle speeds (above stepping speed) is not admissible.

Either a suitable gear is to be shifted immediately, or the vehicle must be stopped at once.

Reversing (Standard):

In the speeds, released for the direct reversing, as a rule in the speeds 1 F \leftrightarrow 1 R and 2 F \leftrightarrow 2 R , it is possible to reverse directly at any time. Reversings in the speeds 3 and 4 are realized dependent on the driving speed, the permitted reversing speed is then normally the maximum speed of the 2nd speed.

- **Beyond the programmed reversing limit, the vehicle will be braked down by the Electronic unit EST-37 by downshiftings, and only then the reversing is carried out into the correspondingly preselected gear.**
- **Below the permitted speed, the reversing will be carried out.**

The programming is customized and can therefore be different from the standard. Therefore, the exact procedure must be taken from the Operating Instructions of the respective Vehicle Manufacturer !

At stopped engine, there is on the Controller, despite a preselected gear, no power flow between transmission and engine, i.e. the transmission is in the idling position.

The parking brake must therefore be completely actuated !

When leaving the vehicle, secure it additionally by brake blocks !

The towing speed must in no case be higher than 10 km/h, the towing distance not longer than 10 km.

It is imperative to observe this Specification because otherwise the transmission will be damaged due to insufficient oil supply !

At a longer distance, the best solution would be to transport the defective vehicle with a Low loader.

Operating temperature behind the converter at least 65° and 100° C in continuous operation, a short-time increase up to max. 120° C is permitted.

Temperature in the sump 60° - 90° C.

In case of irregularities on the transmission, put the vehicle out of service and ask for Specialists.

Protective measures for the ZF-Electronics at electrical operations on the vehicle:

At the following operations, the ignition must be switched off and the control unit plug must be pulled off from the ZF-Electronics:

- * At any kind of electrical operations on the vehicle.**
- * At welding operations on the vehicle.**
- * At insulation tests on the electric system.**

I. DESCRIPTION

1.1 Function of the Converter:

Function of a hydrodynamic Torque converter (Schematic view)

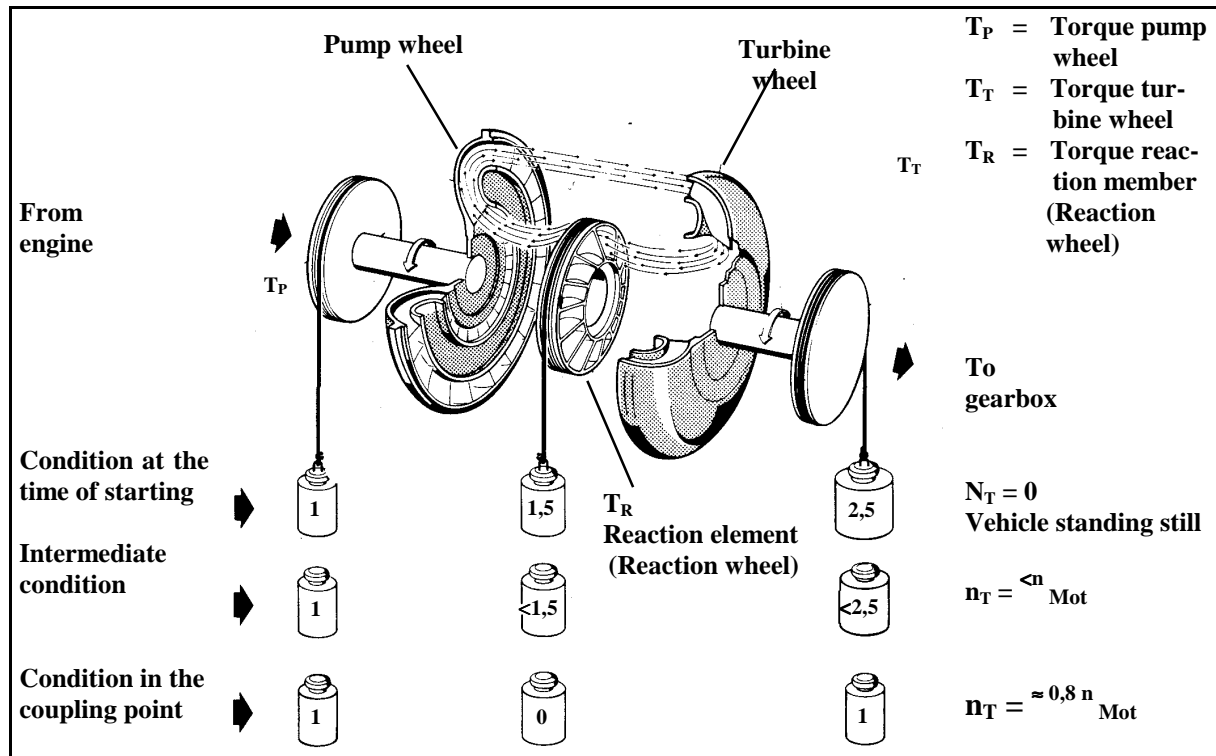

Figure-No. 1.1

The converter is working according to the Trilok-System, i.e. it assumes at high turbine speed the characteristics, and with it the favourable efficiency of a fluid clutch.

The converter is designed according to the engine power so that the most favourable operating conditions are obtained for each installation case.

The Torque converter is composed of 3 main components:
Impeller – Turbine wheel – Stator (Reaction member)

These 3 impellers are arranged in such a ring-shaped system that the fluid is streaming through the circuit components in the indicated order.

Pressure oil from the transmission pump is constantly streaming through the converter. In this way, the converter can fulfill its task to multiply the torque of the engine and at the same time, the heat created in the converter is dissipated via the escaping oil.

The oil which is streaming out of the impeller, enters the turbine wheel and is there reversed in the direction of flow.

According to the rate of reversion, the turbine wheel and with it also the output shaft is receiving a more or less high reaction torque.

The stator (reaction member), following the turbine, has the task to reverse the oil streaming out of the turbine once more and to deliver it under the suitable discharge direction to the impeller.

Due to the reversion, the stator is receiving a reaction torque.

The relation turbine torque/pump torque is called torque multiplication. This is the higher, the greater the speed difference of impeller and turbine wheel will be.

Therefore, the maximum torque multiplication is created at stationary turbine wheel.

With increasing output speed, the torque multiplication is decreasing. The adaption of the output speed to a certain required output torque will be infinitely variable and automatically achieved by the torque converter.

When the turbine speed is reaching about 80% of the pump speed, the torque multiplication becomes 1,0 i.e. the turbine torque becomes equal to that of the pump torque.

From this point on, the converter is working similar to a fluid clutch.

A stator freewheel serves to improve the efficiency in the upper driving range, in the torque multiplication range it is backing-up the torque upon the housing, and is released in the clutch range.

In this way, the stator can rotate freely.

1.2 Powershift transmission:

The multi-speed reversing transmission in countershaft design is power shiftable by hydraulically actuated multi-disk clutches.

All gears are constantly meshing and carried on antifriction bearings.

The gear wheels, bearings and clutches are cooled and lubricated with oil.

The 4-speed reversing transmission is equipped with 6 multi-disk clutches.

At the shifting, the actual plate pack is compressed by a piston, movable in axial direction, which is pressurized by pressure oil.

A compression spring takes over the pushing back of the piston, thus the release of the plate pack. As to the layout of the transmission as well as the specifications of the closed clutches in the single speeds, see Table-1, 7 and 8.

1.3 Transmission control:

Transmission control, see Schedule of measuring points, Oil circuit diagram and Electro-hydraulic control unit see Table-7, 8 and 9.

The transmission pump, necessary for the oil supply of the converter, and for the transmission control, is sitting in the transmission on the engine-dependent input shaft.

The feed rate of the pump is $Q = 105 \text{ l/min}$, at $n_{\text{Engine}} = 2000 \text{ min}^{-1}$.

This pump is sucking the oil via the coarse filter out of the oil sump and delivers it via the ZF-Fine filter – the filter can also be fitted externally from the transmission – to the main pressure valve.

If because of contamination, resp. damage, the through-flow through the ZF-Fine filter is not ensured, the oil will be directly conducted via a filter differential pressure valve (bypass valve $\Delta p = 5,5 \text{ bar}$) to the lubrication.

In this case, an error indication is shown on the ZF-Display.

ZF-Fine filter:

Filtration ratio according to ISO 4572:	$\beta_{30} \geq 75$ $\beta_{15} = 25$ $\beta_{10} = 5.0$
Filter surface at least:	6700 cm ²
Dust capacity according to ISO 4572 at least:	17 g

The six clutches of the transmission are selected via the 6 proportional valves P1 to P6. The proportional valve (pressure regulator unit) is composed of pressure regulator (e.g. Y6), follow-on slide and vibration damper.

The control pressure of 9 bar for the actuation of the follow-on slides is created by the pressure reducing valve. The pressure oil (16+2 bar) is directed via the follow-on slide to the respective clutch.

Due to the direct proportional selection with separated pressure modulation for each clutch, the pressures to the clutches, which are engaged in the gear change, will be controlled. In this way, a hydraulic intersection of the clutches to be engaged and disengaged becomes possible. This is creating spontaneous shiftings without traction force interruption.

At the shifting, the following criteria will be considered:

- Speed of engine, turbine, central gear train and output.
- Transmission temperature.
- Shifting mode (up-, down-, reverse shifting and speed engagement out of Neutral).
- Load condition (full and part load, traction, overrun inclusive consideration of load cycles during the shifting).

The main pressure valve is limiting the max. control pressure to 16+2 bar and releases the main stream to the converter and lubricating circuit.

In the inlet to the converter, a converter safety valve is installed which protects the converter from high internal pressures (opening pressure 11,0 bar).

Within the converter, the oil serves to transmit the power according to the well-known hydrodynamic principle (see Chapter Torque converter 1.1).

To avoid cavitation, the converter must be always completely filled with oil.

This is achieved by a converter pressure back-up valve, rear-mounted to the converter, with an opening pressure of at least 4,3 bar.

The oil, escaping out of the converter, is directed to a heat exchanger.

The selection and definition of the heat exchanger must be carried out according to our Installation specification for hydrodynamic powershift transmissions by the Customer on his own responsibility.

The heat exchanger is not within the scope of supply of the **ZF Passau GmbH**.

From the heat exchanger, the oil is directed to the transmission and there to the lubricating oil circuit, so that all lubricating points are supplied with cooled oil.

In the Electrohydraulic control unit are 6 pressure regulators installed – see Table-9.

The allocation of the pressure regulators to the single speeds can be seen on the Tables 7 and 8.

1.4 Controller

1.4.1 General:

 Due to the great number of the available Controllers, the precise Technical Data must be taken from the respective installation drawing.

1.4.2 Controller DW-3

- see Table-12

The Controller is designed for the mounting on the steering column left side. By a rotative motion, the positions (speeds) 1 to 4 are selected by tilting the lever, the driving direction (Forward (F) – Neutral (N) – Reverse (R)).

The DW-3 Controller is also available with integrated Kickdown pushbutton.

For the protection from unintended start off, a Neutral interlock is installed:

Position „N“ – Controller lever blocked in this position

Position „D“ – Driving

Controller DW-3

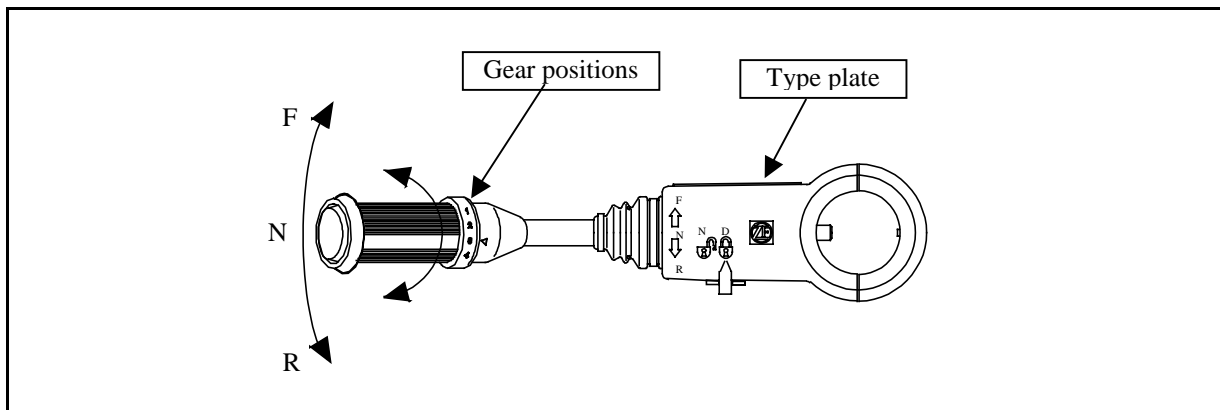

Figure-No.: 1.4.2

1.4.3 Controller ERGO II

- see Table-13

This lever will be installed in the Wheel loader instead of the operating lever for the hydraulic system for implement operation.

By pushing the arrow button „Forward“ and „Reverse“, the driving direction will be selected, the Buttons „+“ and „-“, are preselecting the driving range.

The indication for gear and driving direction is shown on the Display (see 1.5).

By means of the „N“-Button, the transmission is shifting to Neutral.

Gear limitation, if second cabin is activated an the all-wheel drive is engaged.

Another Button on the operating field allows the connection of an electric shovel-horizontal Regulation (Shovel-Neutral). Another function button is installed on the back. It serves, according to the programming, as Kickdown button, Down-shift button or Release button for the start off.

Controller ERGO II

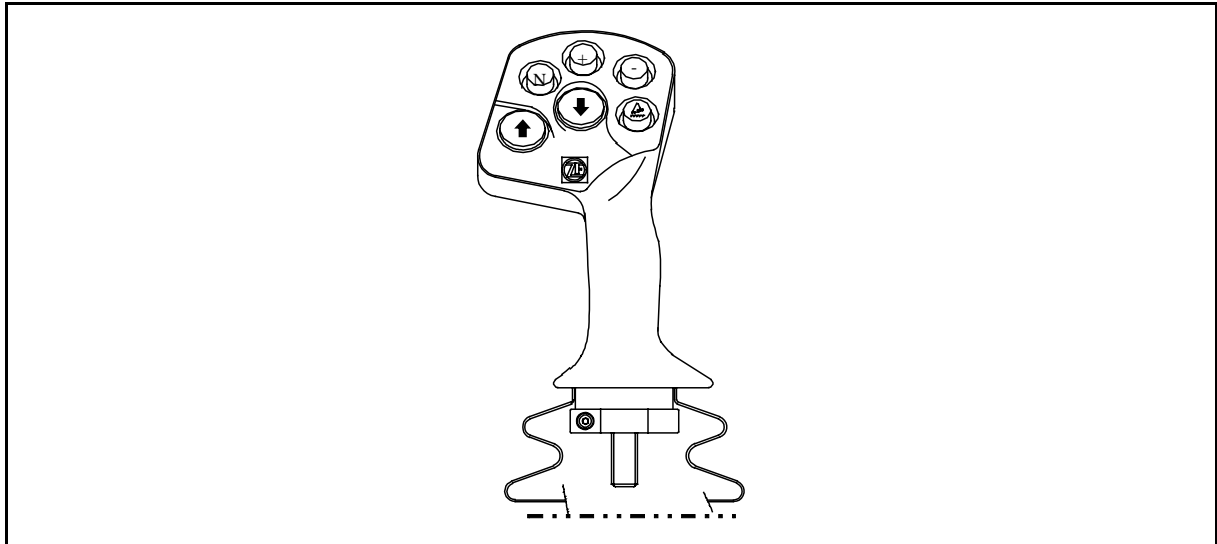

Figure-No.:1.4.3

1.5 Display

1.5.1 General:

The Display can be used with all Controller types, e.g. with the DW-3 or ERGO II for Wheel loaders, Lift trucks, RoRo trucks as well as with the VTS-3, SG-6 or D7 for Cranes, Dumpers, Graders and Rail vehicles.

1.5.2 Possible Indications on the Display

Display

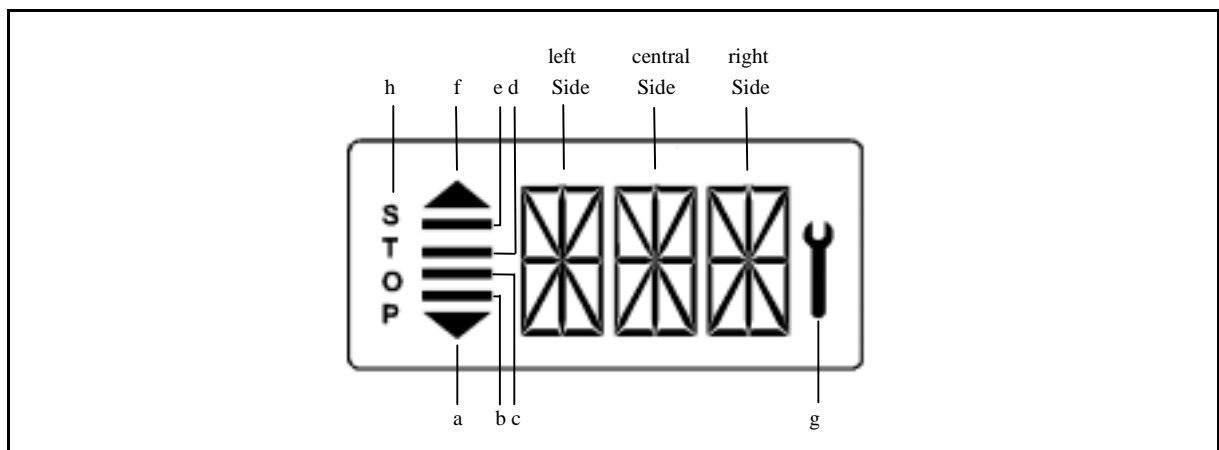

Figure-No.: 1.5.2

Spec. charact.	Display (see Figure-No.: 1.5.2)
a, f	Automatic range (up- and downshifting)
b, c, d, e	Preselected gear
g	EST-37 has recognized an error, is flashing
h	This special character is not used for the moment at the EST-37
Left Side	For the moment still without function
Central and Right Side	On the two alphanumeric 16-segment displays, the EST-37 issues the actual state of gear and driving direction. Besides, a two-digit error code will be indicated via these two segments.

Display of the Driving direction:
(right Side)

V : Forward
N: Neutral
R: Reverse

Display of the engaged gear:
(central Side)

Display 1, 2, 3, 4

Waiting for Controller-Neutral:

Indication on the Display: NN (central and right Side). In this condition, Neutral is pending on transmission. To engage a gear, at first Neutral must be shifted on the Controller before the electronics allows to engage a gear again.

Preselected Driving range:
(Special characters b, c, d, e)

The number of the lines indicates the driving range, resp. the gear preselection:

1 Bar: Manual Mode 1 speed
2 Bars: Manual Mode 2 speed
3 Bars: Manual Mode 3 speed
4 Bars: Manual Mode 4 speed

Display Manual/ Automatic:
(Special characters a, f)

If the two Symbols a, f (Arrows) and the bars b, c, d, e are indicated, the system is in the Automatic mode (automatic up- and downshiftings).

 If the Arrows (a, f) are flashing, the KD (Kick-Down) – Mode is activated.

Display of the Cold-start phase:

Transmission remains in Neutral ✱✱

Bars are flashing:

Downshifting mode active

Error display:

If the system is recognizing an error, the spanner (Special symbol „g“) is flashing.
If Neutral is preselected on the Controller, a two-digit error number appears on the two alphanumeric indicating positions (central and right Side).

If more than one error is pending, the different error numbers will be indicated one after the other on the Display in cycles (about 1 second).

 ***The error code will be only then indicated if the Controller is in Neutral !***

Warning display:

At exceeding the warning threshold Temperature – Sump / behind the Converter and the warning threshold Speed – Engine, changes the indication on the Display to the actual gear and the corresponding warning indicator.

 If several warnings are simultaneously active, only the warning with the highest priority will be indicated.

Warning code	Warning	Priority
WT	Temperature behind Converter	1
WS	Temperature in the Sump	2
WE	Engine speed	3

Display PN

Driving direction F or R selected whilst the parking brake is actuated.

Transmission in Neutral until parking brake will be released.



After the release of the parking brake, the vehicle begins to roll.

F or R flashing

Driving direction F or R selected, whilst the turbine speed is too high.

 Speed will be engaged when the turbine speed is decreasing.

Display EE

Indication on Display: **EE** (central and right side). In this state, the Display has a timeout, i. e. it is receiving no Data from the EST-37.

Main reasons:

- EST-37 is in TOTAL RESETTING MODE (e.g. because of output train disconnection or external power supply at the lines to the gear-solenoid valves).
 - EST-37 without supply
- Data line not correctly connected, etc.

1.5.3 Error code definition:

The error codes are composed of two hexadecimal numbers:

The first number indicates the kind of signal, the second number the signal and the kind of error.

Since there are different Software versions for the Customers, the listing of the error codes must be taken from the Documentation of the Vehicle Manufacturer.

First Number	Meaning of the Number
1 hex	Digital input signal
2 hex	Analog input signal
3 hex	Speed signal
4 hex	CAN signal error
5 hex	CAN signal error
6 hex	CAN signal error
7 hex	Analog current output signal
8 hex	Analog current output signal
9 hex	Digital output signal
A hex	Digital output signal
B hex	Transmission error, Clutch error
C hex	Logical error
D hex	Power supply
E hex	Highspeed signal
F hex	General error

 For the EST-37, a general Diagnostic and Trouble shooting Specification is available, for which the following Order-No. has been defined:

5872 993 025	GERMAN
5872 993 026	ENGLISH

This Diagnostic and Trouble shooting Specification can be requested under the following address:

ZF Passau GmbH
Abt. ASI
Donaustr. 25 – 71

94034 Passau

1.6 Elektronik Control unit TCU

The electrohydraulic transmission control can be automated by connection on the electronic TCU.

The basic functions of the automatic system are the automatic shifting of speeds, adaption of the optimum shifting points, the comfortable kickdown function as well as comprehensive safety functions in relation to operating errors and overloadings of the power-transmitting components with a comprehensive fault storage.

The Control units can be programmed customized and vehicle-specific in a large spectrum, Control parameter can be logically chained, and also Special functions such as gear limitation, Converter or Retarder functions can be integrated.



Because of the great number of available TCU, the precise Technical Data must be taken from the corresponding Installation drawing.

Installation position of the TCU

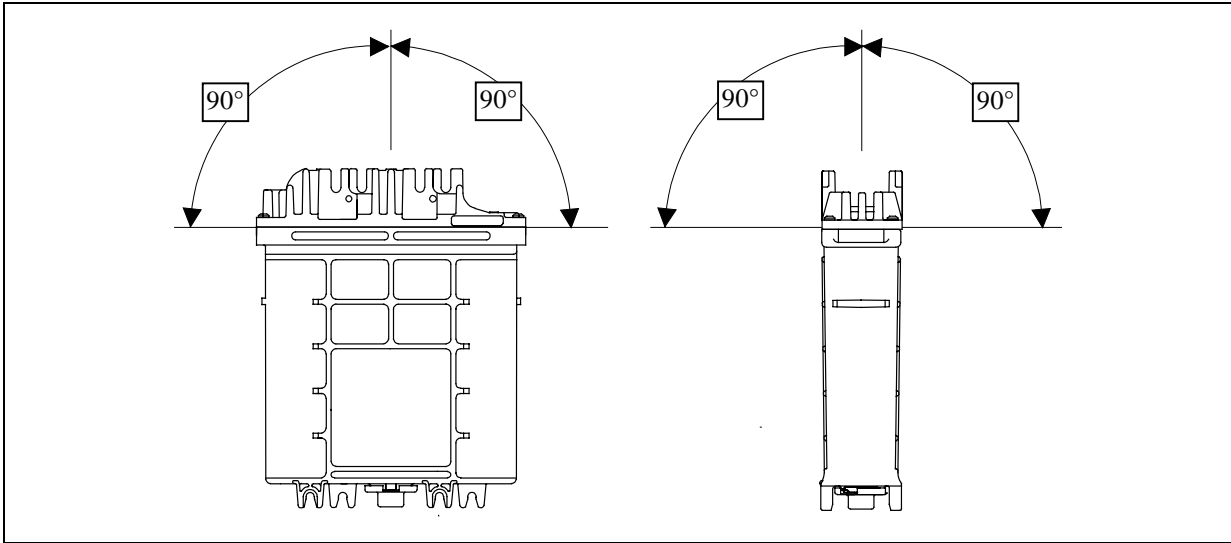

Figure-No.: 1.6 B1

Installation position of the TCU

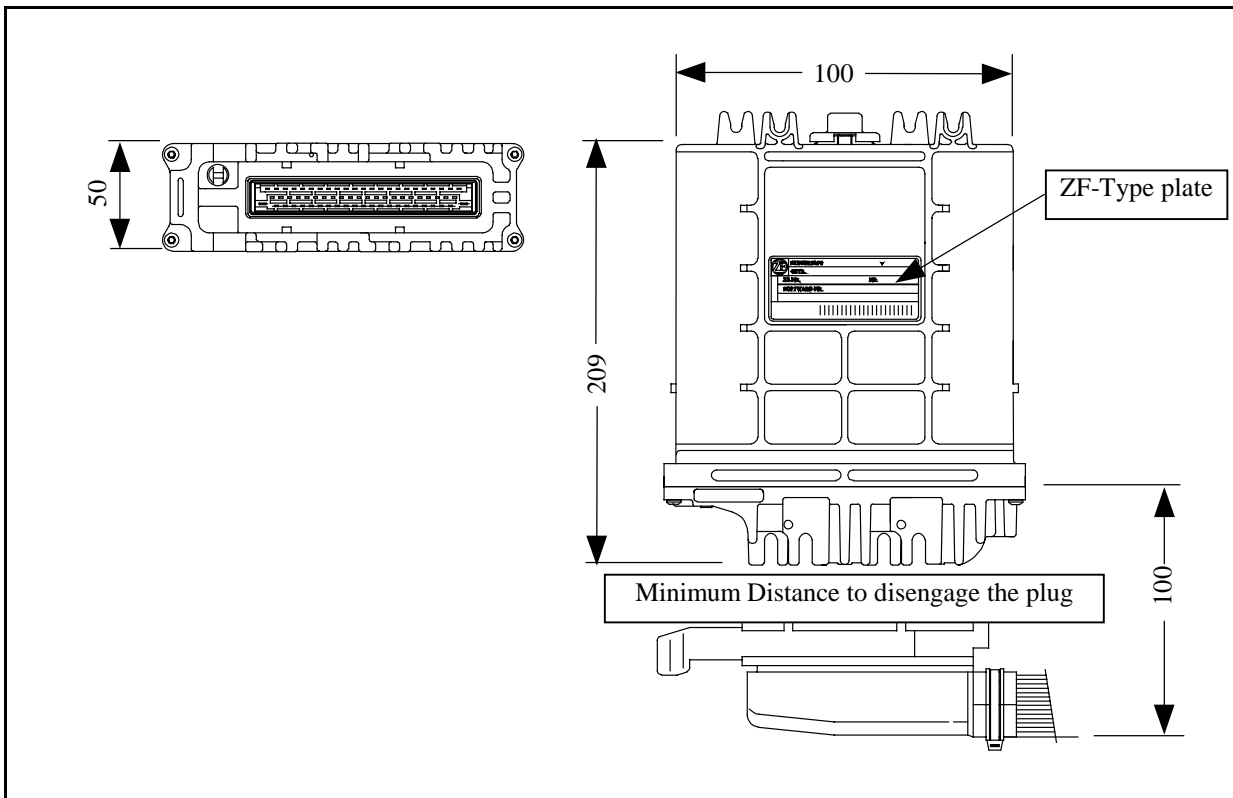

Figure-No.: 1.6 B2



The installation position of the TCU can be at random. As an advantage, the ZF recommends the Version illustrated in the Figure-No.: 1.6 B1.

The installation of the TCU must be realized on a protected point in the cabin.

An overflowing with water must be excluded. Besides, the penetration of water via the plug connection must be prevented by corresponding measures on the cable harness.

1.7 Electronic Controls for ZF-Powershift transmissions:

1.7.1 General:



Because of the different configurations of the electronic transmission controls at the various vehicles, the corresponding documentation must be taken from the operating Instructions of the Vehicle Manufacturer or from the Technical Data sheet of the concerned Parts List Versions. In these are also indicated the respective circuit diagram (see Sample Table-11) - and the connection diagram (upon request, these Informations can be asked for at the ZF Passau).

According to the type of vehicle, the wiring will be performed according to the wiring diagrams.

The corresponding electric circuit diagrams (proposals) will be realized by ZF.

Upon request, the wiring can be also supplied by ZF.

If the wiring will be realized by the Vehicle Manufacturer, it must be in accordance with the ZF-Requirements (see Installation Specification).

1.7.2 Description of the Basic functions:

The Powershift transmission of the Ergopower-Series 4 WG-190/210 is equipped with the Electronic control unit EST-37, developed for it.

For Wheel loaders, Lift trucks and RoRo Trucks, the ZF has developed with the Controllers DW-3 and ERGO II a special Controller configuration.

The system is processing the desire of the driver according to the following criteria:

- Gear determination depending on controller position, driving speed and load condition.
- Protection from operating error as far as necessary, is possible via electronic protection (programming).
- Protection from over-speeds (on the base of engine and turbine speed).
- Automatic reversing (driving speed-dependent, depending on vehicle type).
- Pressure cut-off possible (vehicle-specific, only after contact with ZF).
- Change-over possibility for Auto- / Manual mode.
- Downshifting functions possible.

Legend ref. Figure-No.: 1.7.2

- 1 = Acoustic / optical warning (Option)
- 2 = Display
- 3 = Controller DW-3 (optionally also with Controller e. g. ERGO II possible)
- 4 = Power supply connection
- 5 = Switch for pressure cut-off (Option)
- 6 = Switch for driving program Manual/Automatic (Option)
- 7 = Downshifting functions (Option)
- 8 = TCU
- 9 = CAN-Connection
- 10 = Wiring
- 11 = Diagnosis Mobidig 2001 only for ZF-Service Stations
- 12 = Diagnosis Laptop with ZF-Diagnostic system Testmann
- 13 = Cable to Inductive transmitter Speed Central gear train
- 14 = Cable to Inductive Speed Engine
- 15 = Cable to Inductive transmitter Speed Turbine
- 16 = Cable to Temperature measuring point behind the Converter „No. 63“
- 17 = Cable to Plug connection on the electrohydraulic Control unit
- 18 = Cable to filter contamination switch
- 19 = Cable to Speed sensor Output and Speedometer
- 20 = Ergopower Transmission 4 WG-190/210

Family package of the EST-37

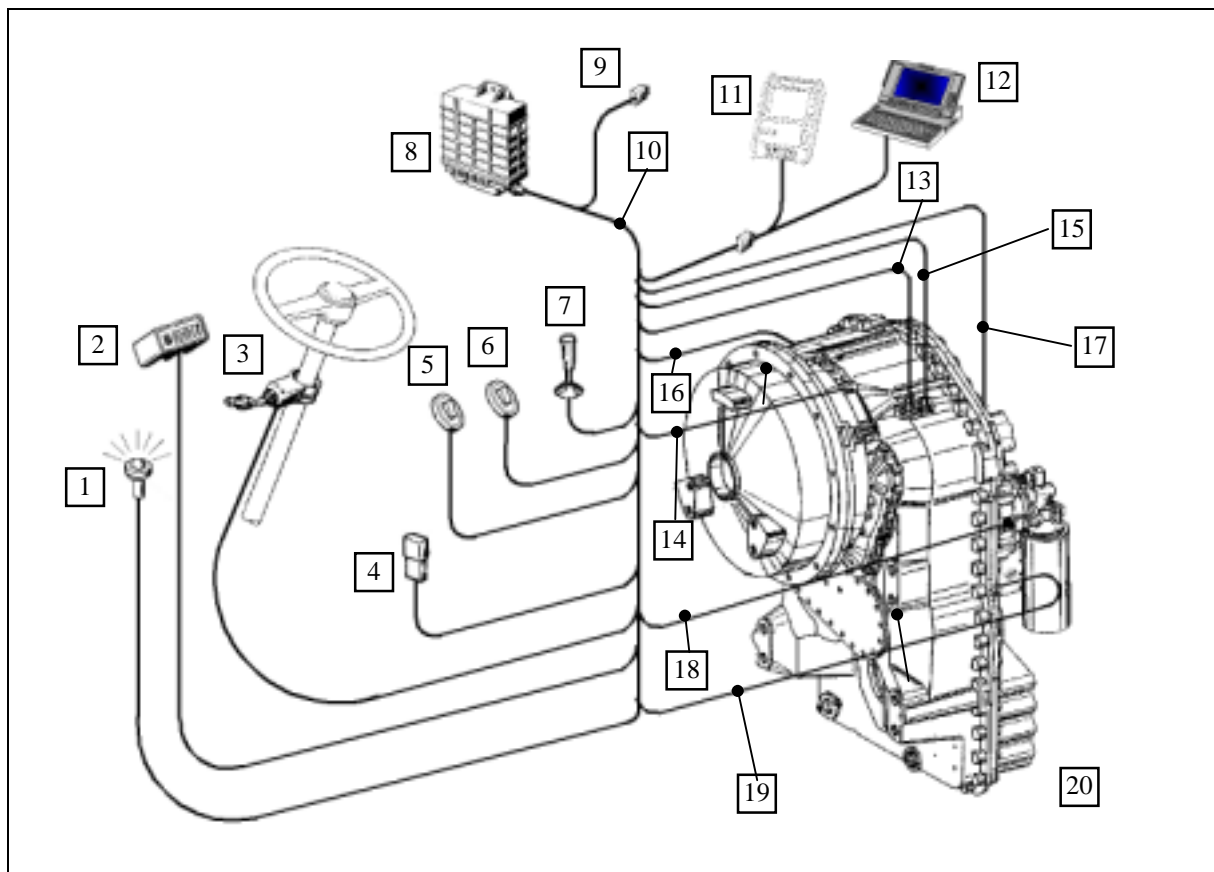



Figure-No.: 1.7.2

1.7.3 Independent calibration of the Shifting elements (AEB)

The AEB has the task to compensate tolerances (plate clearance and pressure level) which are influencing the filling procedure of the clutches. For each clutch, the correct filling parameters are determined in one test cycle for:

- Period of the quick-filling time
- Level of the filling compensating pressure

The filling parameters are stored, together with the AEB-Program and the driving program in the transmission electronics. Because the Electronics will be separately supplied, the AEB-Cycle must be started only after the installation of both components in the vehicle, thus ensuring the correct mating (Transmission and Electronics).

 At any rate, the AEB-Cycle must be carried out at the Vehicle Manufacturer prior to the commissioning of the vehicles.

It is imperative, to respect the following Test conditions:

- Shifting position Neutral
- Engine in idling speed
- Parking brake actuated
- Transmission in operating temperature

 After a replacement of the transmission, the electrohydraulic control or the TCU in the vehicle, the AEB-Cycle must be as well carried out again.

The AEB-Cycle continues for about 3 to 4 minutes. The determined filling parameters are stored in the EEPROM of the Electronics. In this way, the error message F6 shown on the Display will be cancelled also at non-performed AEB.

 For the start of the AEB-Cycle, there are principally two possibilities:

1. Start of the AEB by separate Tools which are connected on the diagnostic port of the wiring.

Following Tools for the AEB start will be offered by the ZF Service.:

- Mobidig 2001 (see Point 5.2 – Diagnostic systems)
- Testmann (see Point 5.3 – Diagnostic systems)
- AEB Starter

Order-No.: **0501 211 778**

The Special Tool, developed by the ZF for it can be used only for the starting of the AEB !
(see Figure-No.: 1.7.3)

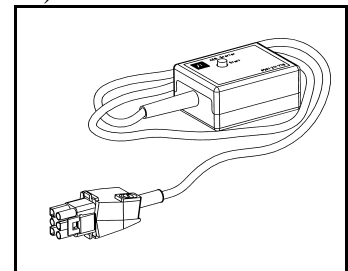

Figure-No.: 1.7.3 B1

2. Start of the AEB by operating elements on the vehicle.
For it, a CAN-Communication between transmission and vehicle electronics is necessary.

- ☞ At the operating of the transmission, the paper friction linings, installed in the Ergo-power transmissions are settling, i.e. the plate clearance becomes greater. Because these settling appearances can affect the shifting quality, ZF recommends to repeat the AEB-Cycle at the Maintenance intervals (see 4.3.1).
- ☞ At a deterioration of the shifting quality, the ZF recommends likewise as first measure to repeat the AEB-Cycle.
- ☞ The AEB can be started from the following Software-No. on:

From the Version 7** on, the AEB can be started with the Tools Laptop and MOBIDIG 2001.
(See Type plate Figure-No. 1.7.3 B2)

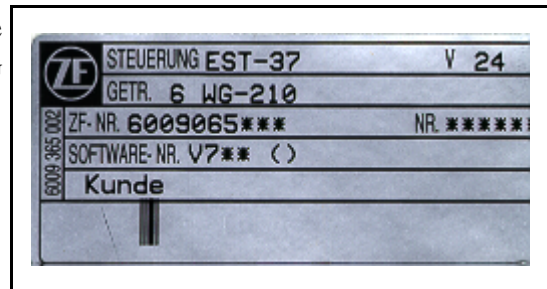

Figure-No.: 1.7.3 B2

From the Version 812 on, the AEB can be started with the Tools Laptop, MOBIDIG 2001 and the AEB-Starter.
(See Type plate Figure-No.. 1.7.3 B3)

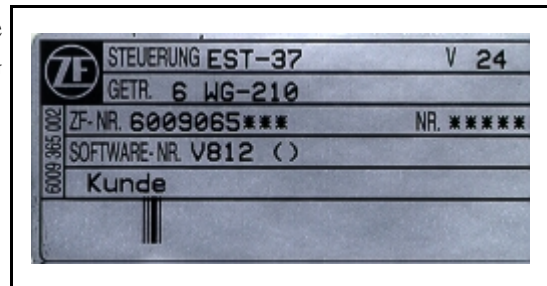

Figure-No.: 1.7.3 B3

1.7.4 Down-Shift functions (Down-Shift Button)

If necessary, it is possible to select from 3 different possibilities:

Down-Shift Button - 1

Function: The downshifting from the second speed (mode manual) into the first speed is performed at the first actuation.
At a second actuation, the upshifting from the first speed into the second speed follows again.

Down-Shift Button - 2 (Quick-Shift Button)

Function: The range limitation on the actual speed will be performed at the first actuation, after a second actuation, the full range is existing again.

Down-Shift Button - 3:

Function: Every actuation is leading to a downshifting for one speed.



The Down-Shift Button (pushbutton) must be in all 3 possibilities provided by the Customer-side, if as Controller the DW-3 or ERGO II with integrated Down-Shift Button will not be used.

1.7.5 Pressure cut-off

In order to provide, e.g. at Shovel loaders, the full engine power for the hydraulic system, the control can be enlarged for the function of a pressure cut-off in the 1st and 2nd speed. In this way, the pressure in the powershift clutches will be cut-off, and the torque transmission in the drive train will be eliminated by it. This function will be released at the actuation of a switch, arranged on the brake pedal. For a soft restart, the pressure will be build-up via a freely programmable characteristic line.

1.7.6 Inching device

This function is especially suitable for Lift trucks. It allows to reduce the driving speed infinitely variable without modification of the engine speed in such a way that driving with a very low speed will be possible. In this way, the driver can move the vehicle very exactly to a determined position.

At the same time, an important part of the engine power for the output of the hydraulic system is at disposal by the high engine speed. The operation is realized via a separate inching pedal. With increasing pedal travel, the driver can reduce the driving speed. The special Software is regulating the pressure in the driving direction clutch in such a way that the driving speed will be adjusted on the inching pedal according to the setting. A clutch overload will be prevented by an integrated protection.

1.7.7 Special functions

According to the desires of the Vehicle Manufacturer, further additional functions can be programmed. Functions such as can be realized:

- * Selection of a Parking brake
- * Automatic Neutral shifting at vehicle standstill
- * Gear range limitation depending on determined Input signals
- * Blocking of the speed engagement beyond a determined Engine speed
- * Upshifting prevention in the overrunning range

Further available Special function upon request after contact with the ZF.

II. INSTALLATION SPECIFICATION

This Specification for the installation of hydrodynamic Powershift transmissions of the Ergo-power-Series is the basis for the technically faultless installation of these transmissions in the vehicle. The Installation Specification is part of the Transmission Documentation and must be absolutely respected.

A faulty installation of the transmission into the vehicle, can

- * affect the operating quality,
- * cause malfunctions of the transmission,
- * lead to transmission damages, resp. transmission failures.

**Responsible for the correct installation of the transmission is the Vehicle Manufacturer.
ZF does not admit any guarantee or warranty claims for damages
which has been caused by a faulty installation.**

In order to assist the Customer in case of new, resp. initial applications, the ZF carries out by authorized personnel a transmission installation check. On this occasion, all transmission-specific installation features are examined and the Vehicle Manufacturer, resp. the Equipment Manufacturer will be informed about the encountered defects.

At improperly installation, ZF reserves itself the right to acknowledge no guarantee for the installed ZF-Products.

For damages, caused by defects for which the Vehicle Manufacturer is responsible, and could not be discovered at the installation examination by ZF-Personnel, the Vehicle Manufacturer alone is liable.

This Installation Specification

0000 702 270 DEUTSCH
0000 702 271 ENGLISCH

can be requested under the following address:

ZF Passau GmbH
Dep. ACETS
e-mail: stefan.altmann@zf.com
Donaustr. 25 – 71
94034 Passau

III. OPERATION

3.1 Driving preparation and Maintenance:

Prior to the commissioning of the transmission, take care that the prescribed oil grade will be filled in with the correct quantity. At the initial filling of the transmission has to be considered that the oil cooler, the pressure filter as well as the pipes must get filled with oil.

According to these cavities, the quantity of oil to be filled in, is greater than at the later oil fillings in the course of the usual Maintenance service.



Because the converter and also the heat exchanger, installed in the vehicle, as well as the pipes can empty at standstill into the transmission, the

Oil level check must be carried out at engine idling speed and operating Temperature of the transmission (see Chapter Oil level check 4.2).



At the oil level check, the prescribed safety directions according to § 6 of the regulations for the prevention of accidents for power plants in Germany, and in all other countries, the respective national regulations have to be absolutely observed.

For example, the vehicle has to be secured against rolling by blocks, articulated vehicles additionally against unintended turning-in.

3.2 Driving and Shifting:



Which control lamps in the INFOCENTER (dashboard) are illuminated for the functional control, can be different from Vehicle Manufacturer to Vehicle Manufacturer.

Control elements and displays can be from the ZF, however can be also customer-specific products; the precise specifications must therefore be taken from the Operating Instructions of the respective Vehicle Manufacturer.

- Neutral position:

Neutral position will be selected via the Controller.

After the ignition is switched on, the electronics remains in the waiting state. By the position

NEUTRAL of the Controller, resp. by pressing the pushbutton NEUTRAL, the EST-37 becomes ready for operation.

Now, a gear can be engaged.

- Starting:

The starting of the engine has always to be carried out in the NEUTRAL POSITION of the Controller.

For safety reasons it is to recommend to brake the vehicle securely in position with the parking brake prior to start the engine.

After the starting of the engine and the preselection of the driving direction and the gear, the vehicle can be set in motion by acceleration.

At the start off, the converter takes over the function of a master clutch.

On a level road it is possible to start off also in higher gears.

- **Upshifting under load.**

Upshifting under load will be then realized if the vehicle can continue to accelerate by it.

- **Downshifting under load.**

Downshifting under load will be then realized if more traction force is needed.

- **Upshifting in overrunning condition.**

In the overrunning mode, the upshifting will be suppressed by accelerator pedal idling position, if the speed of the vehicle on a downgrade should not be further increased.

- **Downshifting in overrunning condition.**

Downshifting in overrunning mode will be then carried out if the vehicle should be retaded.

- **Reversing**

See important Note – Page 9.

If the vehicle will be stopped and is standing with running engine and engaged transmission, the engine cannot be stalled. On a level and horizontal roadway it is possible that the vehicle begins to crawl, because the engine is creating at idling speed a slight drag torque via the converter.

It is convenient to brake the vehicle at every stop securely in position with the parking brake.

At longer stops, the Controller has to be shifted to the NEUTRAL POSITION.

At the start off, the parking brake has to be released. We know from experience that at a converter transmission it might not immediately be noted to have forgotten this quite normal operating step because a converter, due to its high ratio, can easily overcome the braking torque of the parking brake.

Temperature increases in the converter oil as well as overheated brakes will be the consequences to be find out later.

Neutral position of the selector switch at higher vehicle speeds (above stepping speed) is not admissible.

Either a suitable gear is to be shifted immediately, or the vehicle must be stopped at once.

3.3 Cold start:

At an oil temperature in the shifting circuit $< -12^{\circ}\text{C}$, the transmission must be warmed-up for some minutes.

This must be carried out in Neutral with an increased engine speed (about 1500 min^{-1}).

Until this oil temperature is reached, the Electronics remains in Neutral, and the symbol of the cold start phase will be indicated on the ZF-Display.

Indication on the Display : 

After the indication on the ZF-Display is extinguished, the full driving programm can be utilized out of „NEUTRAL“.

3.4 Transmission control in the Driving mode Automatic:



Precise Informations about the design of the Controllers as well as the speeds shifted in the single driving ranges, must be taken from the Operating Instructions belonging to the vehicle.

A manual intervention into the automatic shift sequence is only then practical if the roadway condition or the configuration of the ground is suitable.

3.5 Stopping and Parking:

Since due to the converter there is no rigid connection existing from the engine to the axle, it is recommended to secure the vehicle on upgrades, resp. downgrades against unintended rolling not only by applying the parking brake but additionally by a block on the wheel, if the driver has the intention to leave the vehicle.

3.6 Towing:

See Important Instructions – Page-10.

3.7 Oil temperature:

The oil temperature in the transmission sump is monitored by a temperature sensor in the electrohydraulic control unit.

The service temperature in the sump of 60° - 90° C must not be exceeded (indication appears on the Display in the cabine) !

At a trouble-free unit and an adequate driving mode, a higher temperature will not occur. If the temperature is rising above 90° C, the vehicle has to be stopped and controlled for external oil loss and the engine must run with a speed of 1200 – 1500 min⁻¹ at NEUTRAL POSITION of the transmission.

Now, the temperature must drop quickly (in about 2 – 3 minutes) to normal values. If this is not the case, there is a trouble pending, which must be eliminated prior to continue working.

The monitoring of the oil temperature is additionally realized behind the converter with an indication on the ZF-Display or analog in the INFOCENTER.

Operating temperature behind the converter at least 65° C and 100° C in continuous operation, a short-time increase up to max. 120° C is permitted.

The temperature is measured on the measuring point **„63“**
(see Schedule of measuring points – Table-8 !)

IV. MAINTENANCE

4.1. Oil grade:

-  Permitted for the Powershift transmissions 4 WG-190/210 are oils according to ZF-List of lubricants TE-ML 03.

-  The list of lubricants is being continuously updated and can be obtained or viewed as follows:
 - At all ZF-Plants
 - At all ZF-Service Stations
 - Internet <http://www.zf.com> **Informationen/Tech. Informationen**

4.2 Oil level check (measurements only with running engine):



At the oil level check, the prescribed safety directions according to § 6 of the rules for accident prevention for power plants in Germany, and in all other countries the respective national regulations have to be absolutely respected. For example, the vehicle has to be secured against rolling with blocks, articulated vehicles additionally against unintended turning-in.

The oil level check must be carried out as follows:

- Oil level check (weekly)
- At horizontally standing vehicle
- Transmission in Neutral position „N“
- In the cold start phase, the engine must be running about 2 – 3 minutes at idling speed, and the marking on the oil dipstick must then be lying above the cold start mark „COLD“ (see Figure-No. 4.2 B2)
- At operating temperature of the transmission (about 80° - 90° C)



With engine idling speed

all measurements must be carried out with low engine idling speed.

- Loosen oil dipstick by counterclock rotation, remove and clean it
- Insert oil dipstick slowly into the oil level tube until contact is obtained, and pull it out again.
- On the oil dipstick, the oil level must be lying in the zone „HOT“ (see Figure-No.: 4.2 B2)
- Insert the oil dipstick again, and tighten it by clockwise rotation



If the oil level has dropped in operating temperature condition below the „HOT“ Zone, it is absolutely necessary to replenish oil according to the ZF-List of lubricants TE-ML-03.

An oil level above the „HOT“ marking, is leading to a too high oil temperature.



The oil dipstick and the oil filler tube can have different lengths and shapes, according to the Transmission version. Besides, the mounting on the transmission can be optionally realized on the converter side or on the rear side.(In this Illustration, the mounting of the oil dipstick is illustrated on the rear side).

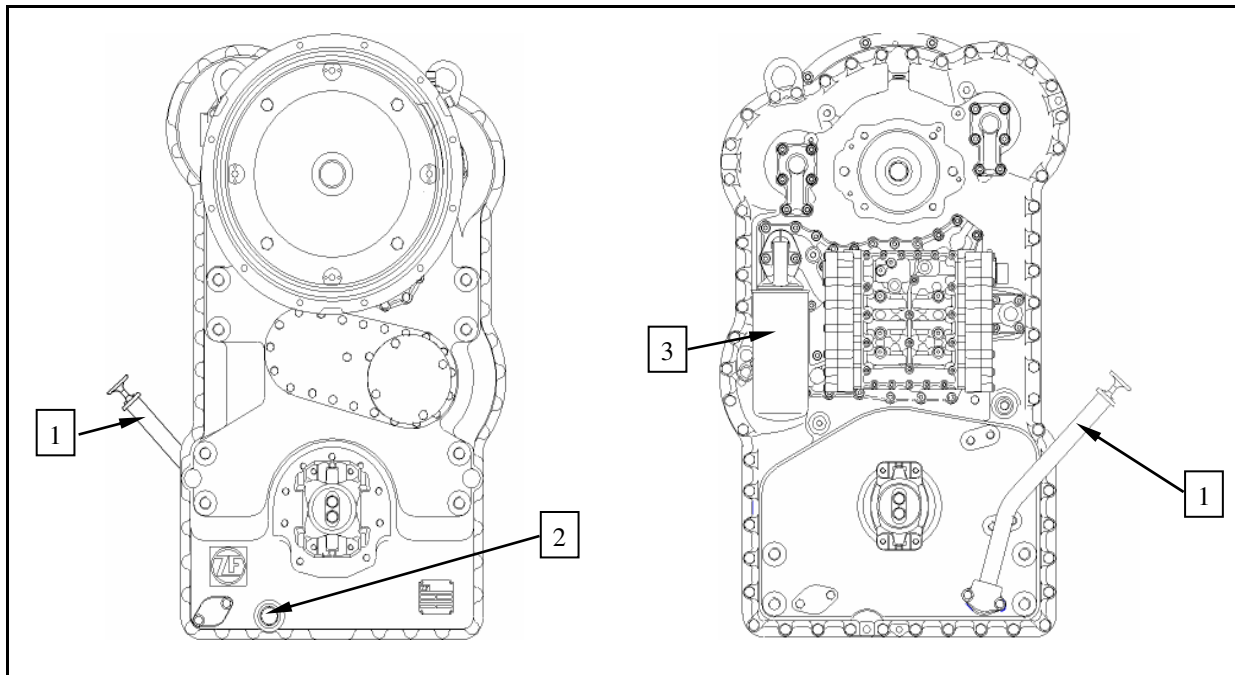

Figure-No.: 4.2 B1

Legend:

- 1 = Oil filler tube with oil dipstick
- 2 = Oil drain plug M32x2
- 3 = ZF-Fine filter (Pressure filter)

Oil dipstick

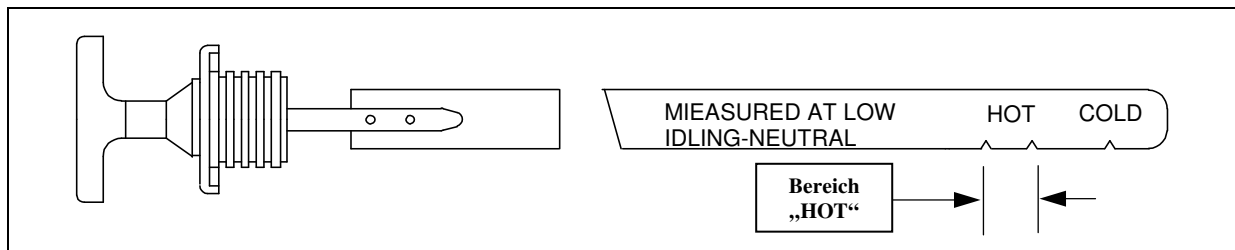

Figure-No.: 4.2 B2

4.3 Oil change and Filter replacement intervals:

 **In this connection refer to specification in the ZF List of Lubricants TE-ML 03. The ZF filter must be replaced at every oil change.**

4.3.1 Oil change and Oil filling capacity:

The oil change has to be carried out as follows:

- At operating temperature of the transmission, horizontally standing vehicle open the oil drain plug and drain the used oil.
- Clean oil drain plug with magnetic insert and surface on the housing and install again along with O-ring.

- Fill in oil (about 21 liters) according to ZF-List of lubricants TE-ML 03.
(Sump capacity, external oil capacities e.g. in the heat exchanger, in the lines etc. are dependent on the vehicle).
The indicated value is a guide value.

 **It is imperative to pay attention to absolute cleanliness of oil and filter !
Binding is in any case the marking on the oil dipstick !**

- Start the engine – idling speed
- Transmission in Neutral position „N“
- Top up oil up to the marking „COLD“
- Brake the vehicle securely in position and warm up the transmission
- Shift all Controller positions through
- Check the oil level once more and top up oil once more if necessary
- On the oil dipstick, the oil level must be lying in the Zone „HOT“ (see Figure-No.: 4.2 B2)
- Insert the oil dipstick again and tighten it by clockwise rotation.

 At the initial filling of the transmission has to be considered that the heat exchanger, the pressure filter as well as the pipes must get filled with oil.
According to these cavities, the oil capacity to be filled in is greater than at the later oil fillings in the course of the usual Maintenance service.

 **ZF recommends, to start the AEB at every oil change (see 1.7.3).**

4.3.2 Filter replacement:

At the replacement of the ZF-Filter in the main oil stream, pay attention that no dirt or oil sludge can penetrate into the circuit. Besides, the parking brake has to be covered, resp. protected from oil wetting.

At the mounting of the filter, any exertion of force has to be avoided.

 The filters are installed separately from the transmission in the vehicle !

 Treat the filter carefully at the installation, the transport and the storage !
Damaged filters must no more be installed !

 The filter differential pressure valve (bypass valve) is equipped with a maintenance-switch (opening switch) which is informing the driver about the contamination of the ZF-Fine filter.

At the lighting up of the symbol, the ZF-Fine filter must be replaced.

The mounting of the filter must be carried out as follows:

- Cover the gasket with a small amount of oil.
- Screw the filter in until contact with the sealing surface is obtained and tighten it now by hand about 1/3 to 1/2 turn.

V. ZF-DIAGNOSTIC SYSTEMS

5.1 General:

The Control electronics EST-37 for the Transmission Series Ergopower is equipped with a diagnostic package, which makes the Trouble shouting and the Repair of damages easier for the Service.

The Electronics is able to monitor the states of certain inputs and outputs.

If the Electronics recognizes at it an error, it stores an error code in the fault storage (EEPROM) and is transmitting the error code also to the vehicle controller of the Vehicle Manufacturer.

The ZF-Diagnostic and Programming systems MOBIDIG-2001 (see 5.2) and LAPTOP-Version (see 5.3) are needed for the following applications:

- | | |
|---|--|
| <p> <u>Diagnosis</u></p> <p><u>AEB</u></p> <p><u>Testing Inputs and Outputs</u></p> | <ul style="list-style-type: none"> - Read actual errors - Read fault storage - Cancel fault storage - Independent calibration of the shifting elements - Check Outputs - Check Inputs - Check systems downtime - System test drive |
|---|--|

Additionally for the Diagnosis can be used the Multi-System 5000 (see 5.4) with corresponding sensor system for pressure, temperature, speed, through-flow, current transformer etc.

5.2 ZF - MOBIDIG 2001

-  The ZF-Diagnostic system MOBIDIG 2001 is only reserved to ZF-Service Stations. All necessary, transmission-specific Data for a quick and comprehensive Diagnosis can be retrieved with this Diagnostic system.

The Data are stored on CD-Rom and will be updated 2 – 3 times a year.

It is universally to be used for all diagnosis-capable ZF-Vehicle systems.

<p>MOBIDIG 2001 with ZF-Diagnostic Software</p>  <p>Diagnostic Software with Operator guidance</p>	<p>6008 307 001</p>	
<p>Terminal tester 68-pin</p> <p>For the test of single control signals, line connections etc.</p>	<p>6008 304 038</p>	

Figure-No.: 5.2

5.3 Laptop Version:





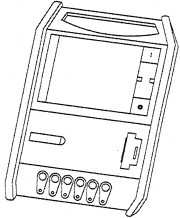
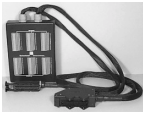



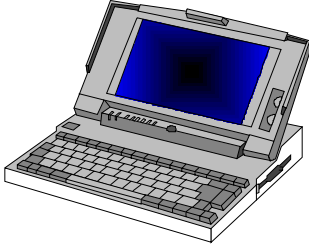
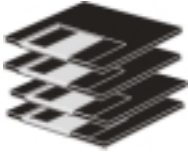

	<p>Specialized Dealers</p>	<p>Pentium Laptop min. 90 MHz Windows 95/98 or NT</p>
	<p>Basic-Software Testman WIN 95/98 or NT 6008 308 901</p>	<p style="text-align: center;">} Diagnostic set 5870 221 179 WIN 95/98 or NT</p>
	<p>RS-232 Connecting cable Laptop ↔ DPA-04I 6008 308 601</p>	
	<p>Programming adapter DPA-04I 6008 308 600</p>	
	<p>Adapter cable DPA-04I ↔ EST-37 6029 017 005</p>	
<p><u>Diagnostic Software WG-190/210</u></p>		
	<p>6008 308 007</p>	<p>GERMAN</p>
	<p>6008 308 107</p>	<p>ENGLISH</p>
	<p>6008 308 207</p>	<p>FRENCH</p>
	<p>Terminal Tester 68-pin For the test of single control signals, line interruptions etc.</p>	<p>6008 304 038</p>

Figure-No.:5.3

5.4 ZF-Multi-System 5000:

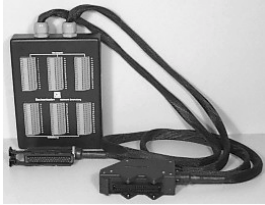
	<p>Multi- System 5000</p> <p>Measuring box with corresponding sensor system for pressure, temperature and speed <i>without</i> printer.</p> <p>5870 221 280</p>
	<p>Multi- System 5000</p> <p>Measuring box with corresponding sensor system for pressure, temperature and speed <i>with</i> printer.</p> <p>5870 221 281</p>
	<p>Multi - System 5000</p> <p>Portable measuring instrument without accessories.</p> <p>5870 221 250</p>
<p>Accessories: Sensor system for through-flow, current transformer etc.</p>	



 <p>Current transformer: 5870 221 284</p>	<p>Turbine – Metering tubes: 15 – 300 l/min = 5870 221 133 25 – 600 l/min = 5870 221 134</p> 
---	---

Figure-No.: 5.4



ERGOPOWER

Geschäftsbereich
Arbeitsmaschinen-Antriebe
und Achssysteme



APPENDIX

TABLE – 1 TO 14

LAYOUT 4 WG-190/210

TABLE - 1

- 1 = Clutch shaft "KR"
- 2 = Power takeoff, coaxial engine dependent
- 3 = Clutch shaft "KV"
- 4 = Clutch shaft "KV"
- 5 = Clutch shaft "K3"
- 6 = Output flange - rear
- 7 = Output flange - converter side
- 8 = Output shaft
- 9 = Transmission pump
- 10 = Input flange - input through universal shaft
- 11 = Converter
- 12 = Inductive transmitter for engine speed
- 13 = Clutch shaft "K4"
- 14 = Converter relief valve
- 15 = Clutch shaft "K1"

GEAR PATTERN

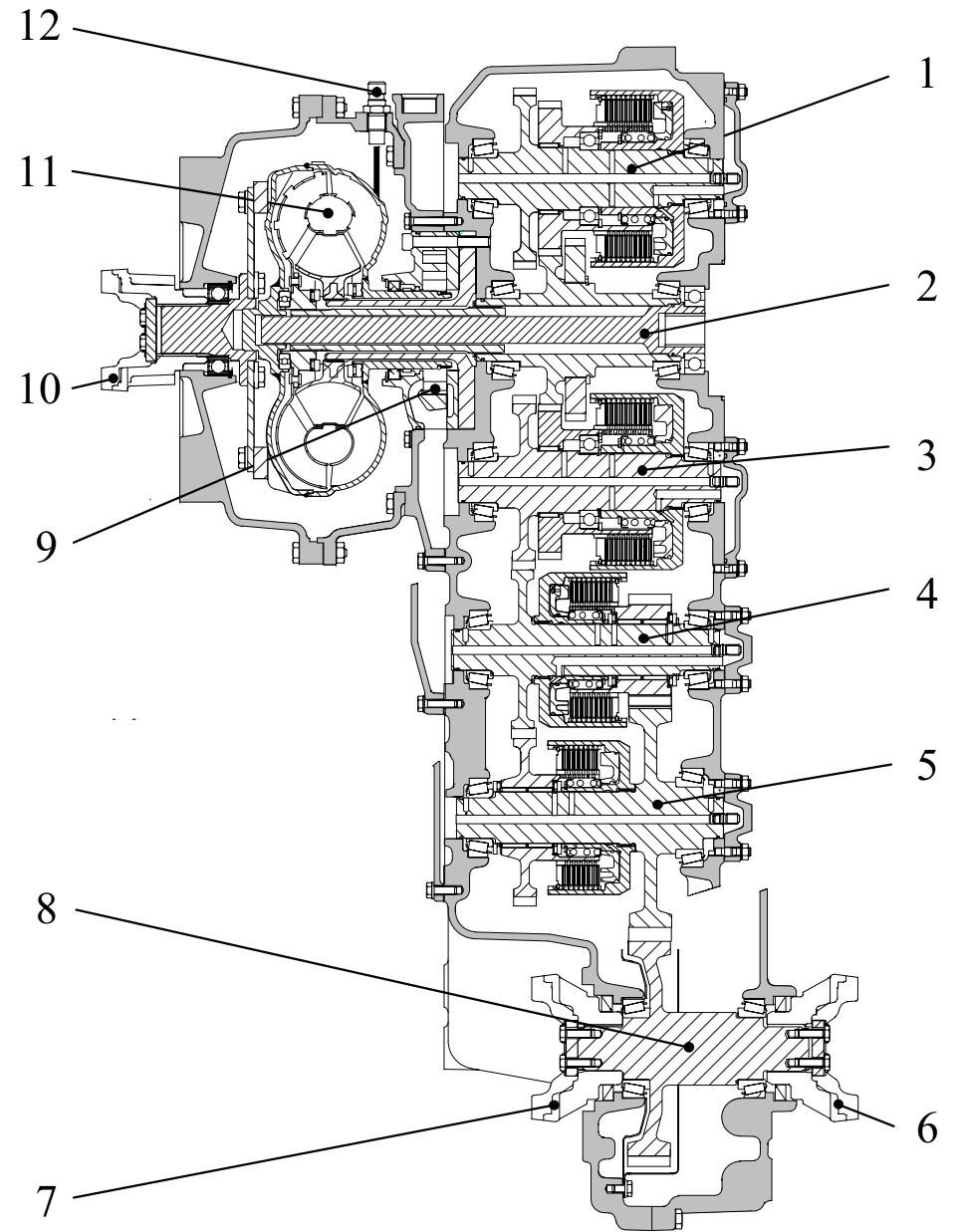
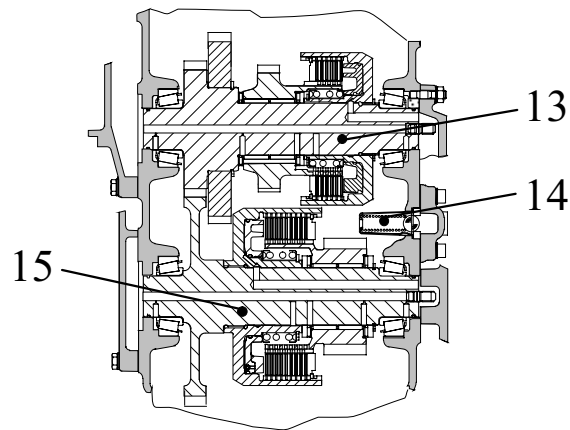
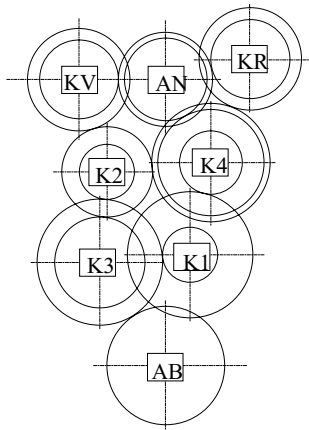

INSTALLATION VIEW 4 WG-190/210 - DIRECT INSTALLATION

FRONT VIEW

TABLE-2

- 1 = Lifting lugs
- 2 = Diaphragm – direct mounting
- 3 = Transmission suspension holes M20
- 4 = Attachment possibility for emergency steering pump
- 5 = Model identification plate
- 6 = Output flange (converter side)
- 7 = Oil drain plug with magnet M38x1,5
- 8 = Attachment possibility for oil filler tube with oil dipstick
- 9 = Oil filler tube with oil dipstick (rear side)
- 10 = Converter

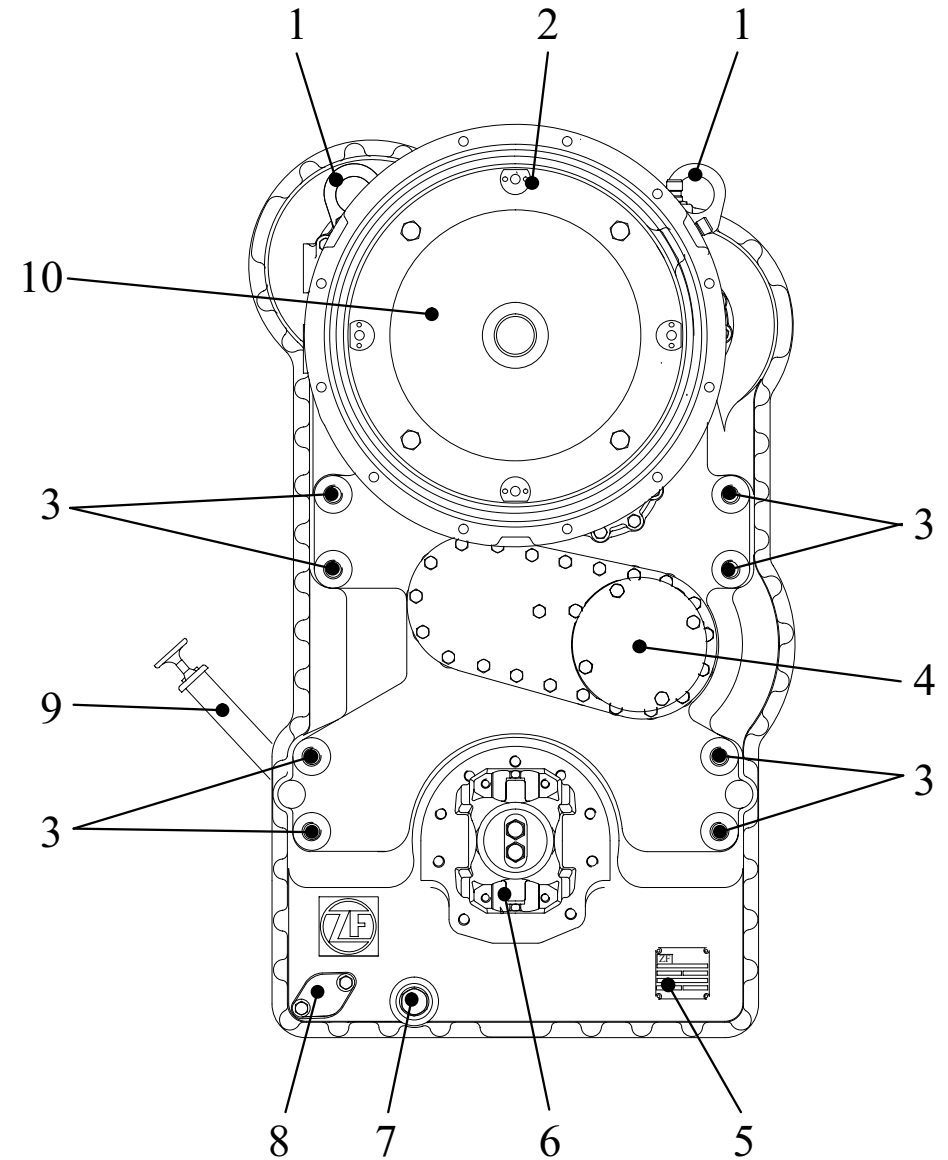

INSTALLATION VIEW 4 WG-190/210 DIRECT INSTALLATION

FRONT VIEW

TABLE-3

- 1 = Lifting lugs
- 2 = Input flange – drive via universal shaft
- 3 = Transmission suspension holes M20
- 4 = Emergency steering pump
S = M33x2
D = M22x1,5
- 5 = Model identification plate
- 6 = Output flange (converter side)
- 7 = Oil drain plug with magnet M38x1,5
- 8 = Attachment possibility for oil filler tube with oil dipstick (converter side)

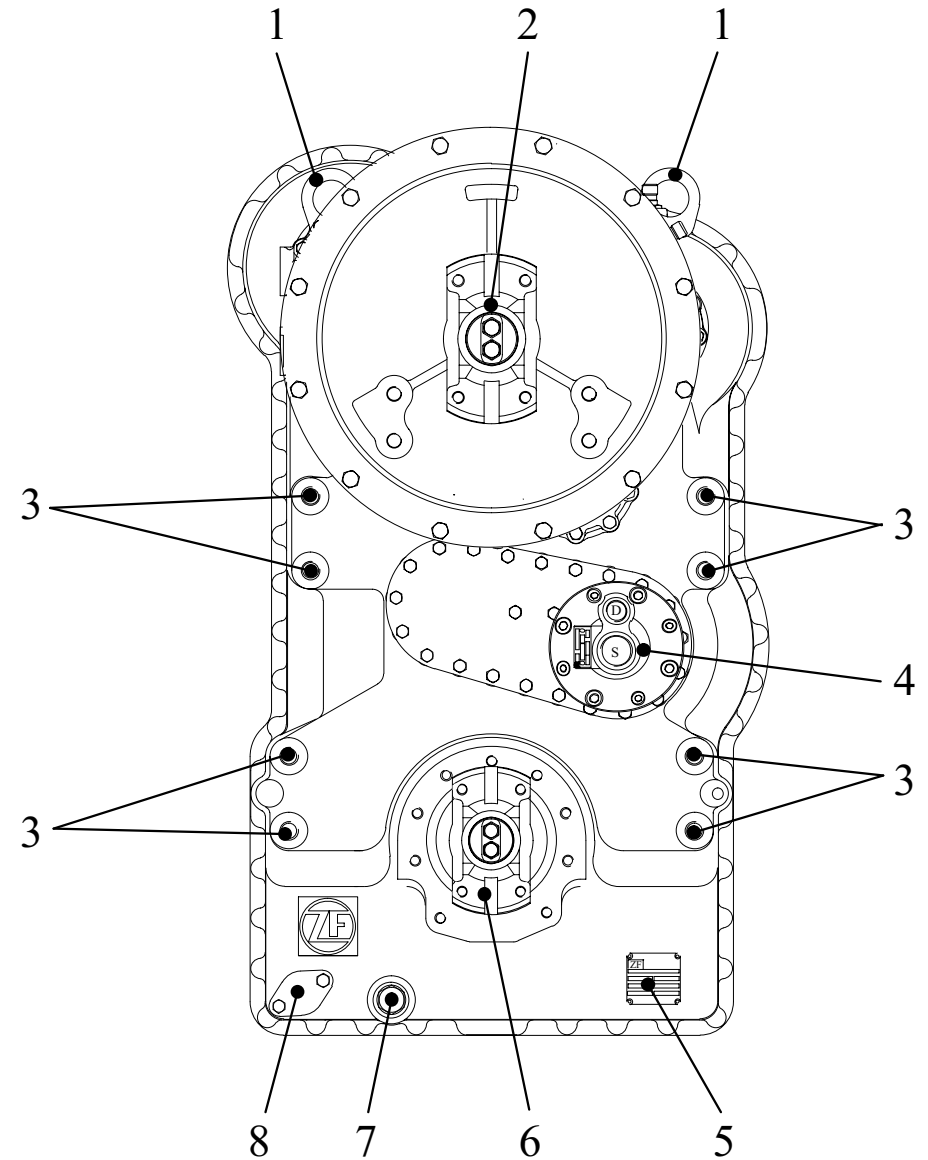

INSTALLATION VIEW 4 WG-190/210 STANDARD VERSION

REAR VIEW

TABLE-4

- 1 = Lifting lugs
- 2 = Power take-off, coaxial engine-dependent
- 3 = Electro-hydraulic control
- 4 = Connection return line from parking brake M26x1,5
- 5 = Oil filler tube with oil dipstick
- 6 = Transmission suspension holes M20
- 7 = Output flange (rear side)
- 8 = Exchange filter (fine filter)
- 9 = Filter head with
- 10 = Connection system pressure M16x1,5

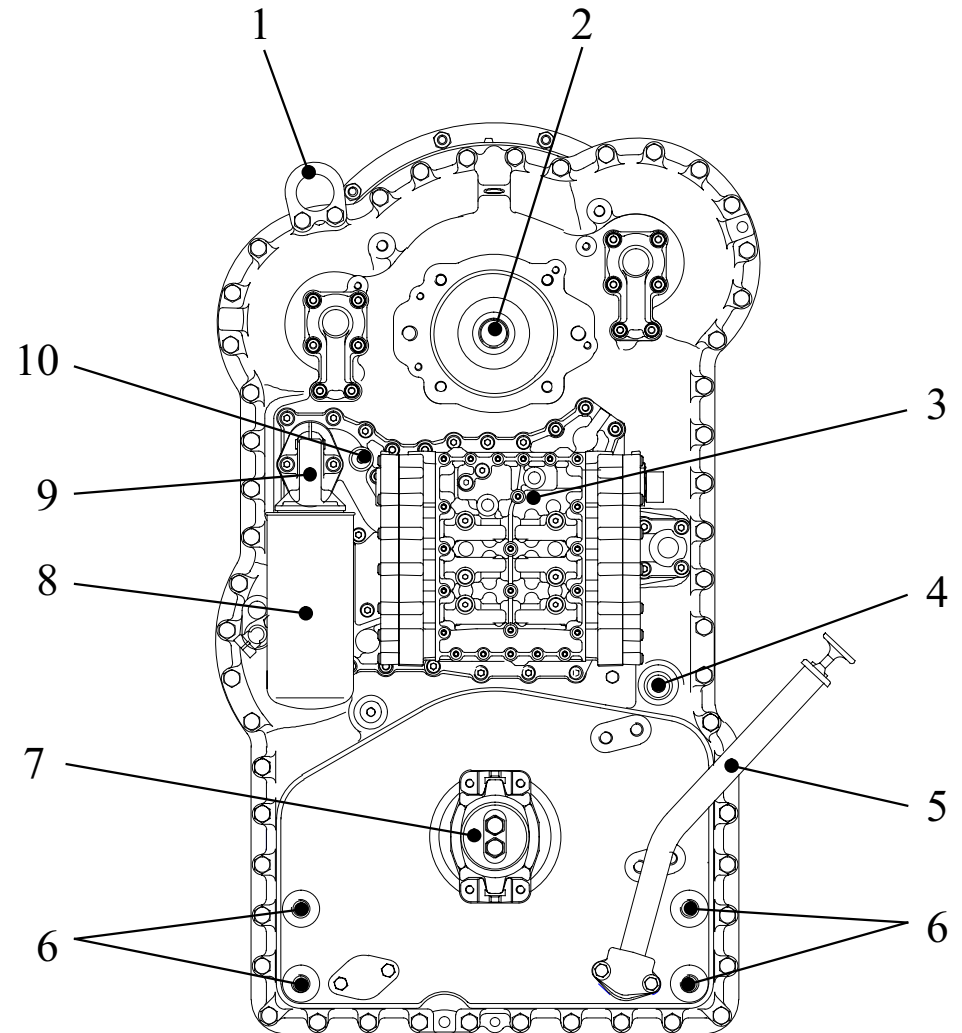

INSTALLATION VIEW 4 WG-190/210 WITH DISC BRAKE

REAR VIEW

TABLE-5

- 1 = Lifting lugs
- 2 = Power take-off, coaxial engine-dependent
- 3 = Electro-hydraulic control
- 4 = Connection return line from parking brake M26x1,5
- 5 = Parking brake operated hydraulically
- 6 = Transmission suspension holes M20
- 7 = Attachment possibility for oil filler tube with oil dipstick (rear side)
- 8 = Brake disc
- 9 = Output flange (rear side)
- 10 = Exchange filter (fine filter)
- 11 = Filter head with
- 12 = Connection system pressure M16x1,5

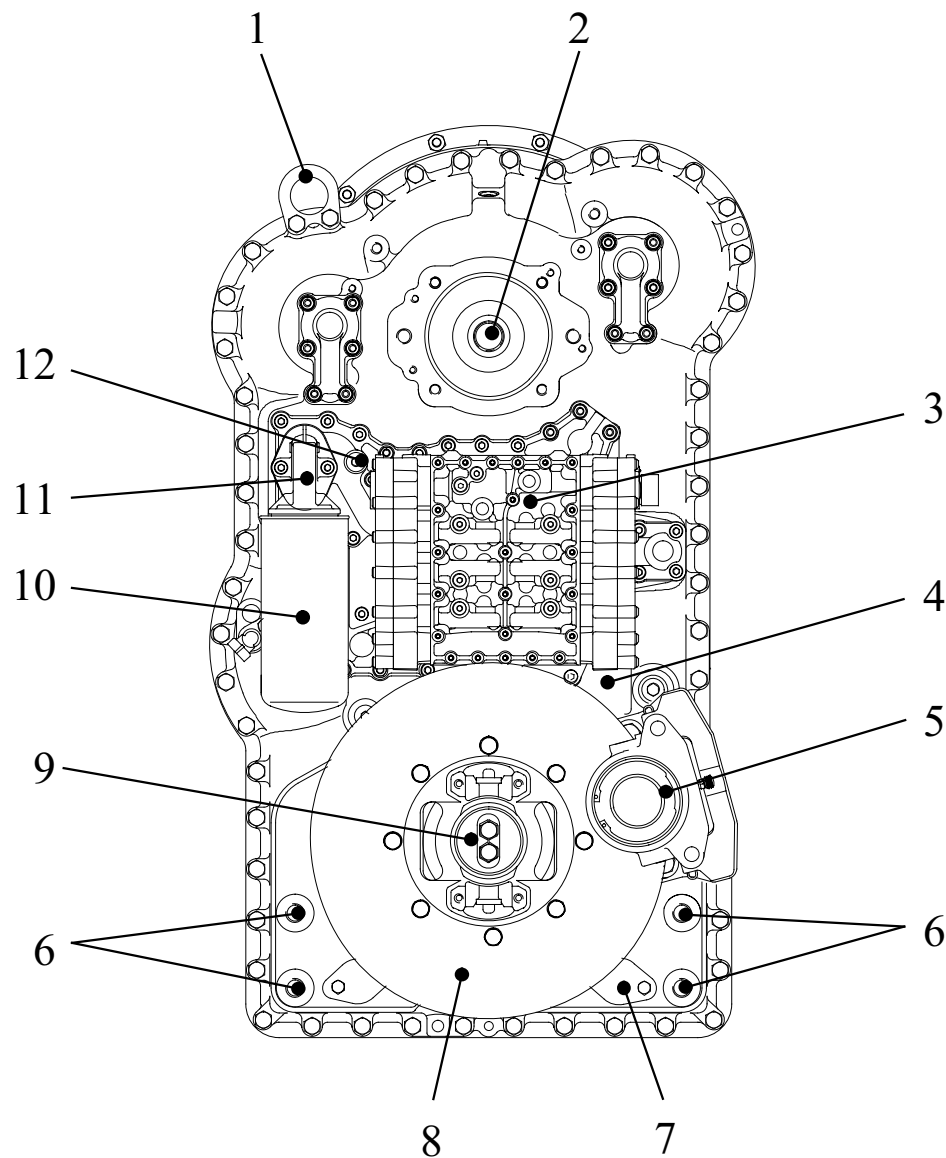

INSTALLATION VIEW 4 WG-190/210 - WITH 1. AND 2. POWER TAKE-OFF REAR VIEW

TABLE-6

- 1 = Lifting lugs
- 2 = 2. Power take-off, coaxial engine-dependent
- 3 = Electro-hydraulic control
- 4 = Connection return line from parking brake M26x1,5
- 5 = Parking brake operated hydraulically
- 6 = Transmission suspension holes M20
- 7 = Attachment possibility for oil filler tube with oil dipstick (rear side)
- 8 = Brake disc
- 9 = Output flange (rear side)
- 10 = Exchange filter (fine filter)
- 11 = Filter head with
- 12 = Connection system pressure M16x1,5
- 13 = 1. Power take-off, coaxial engine-dependent

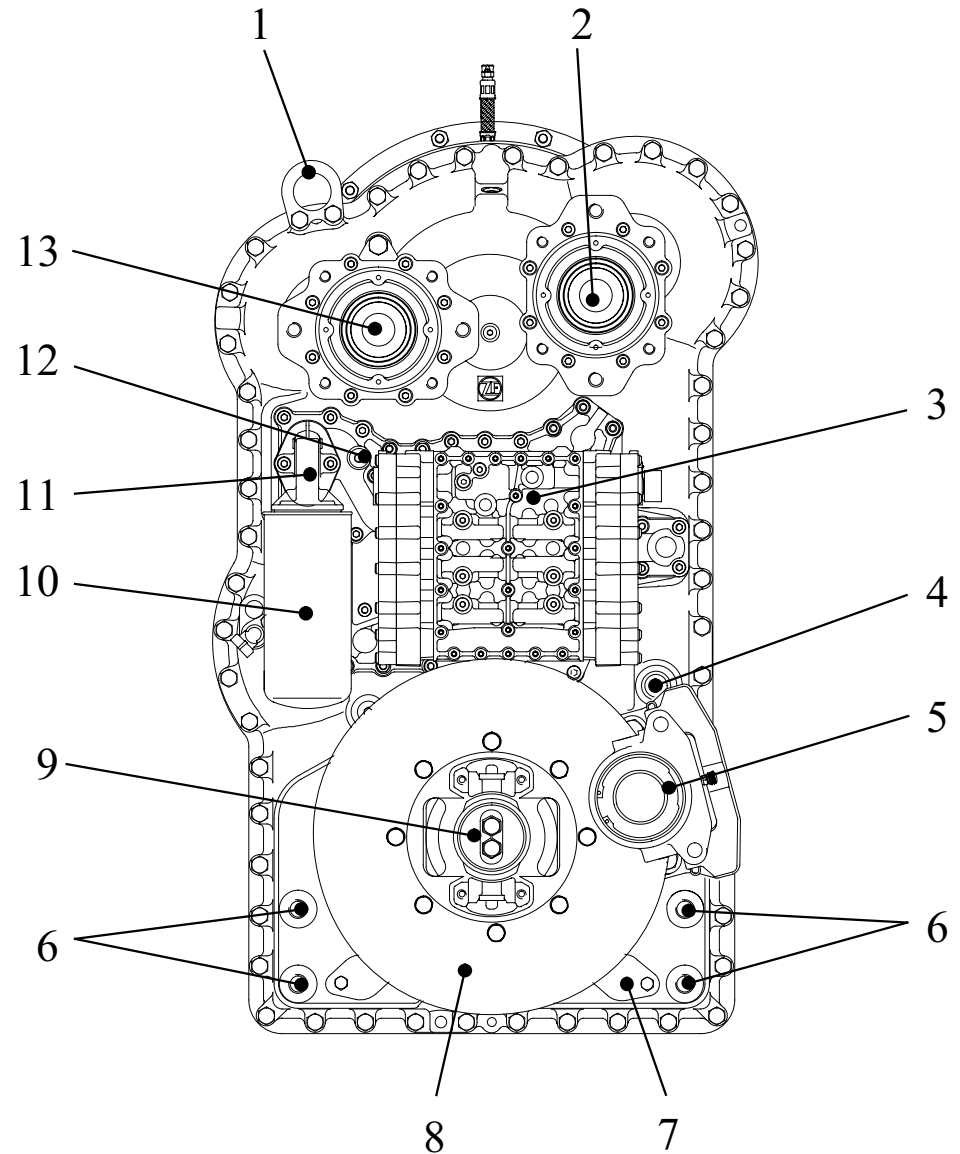

SCHEDULE OF MEASURING POINTS AND CONNECTIONS 4 WG-190/210

TABLE-7

The marked positions (e.g. 53) correspond with the positions on the table-8!
 The measurements have to be carried out at hot transmission (about 80° - 95° C)!

NO.	DENOMINATION OF THE POSITION	CONNECTION	MARKING ON THE VALVE BLOCK
MEASURING POINTS FOR HYDRAULIC OIL AND TEMPERATURE:			
51	= In front of the converter – opening pressure	11 bar M10x1	H
52	= Behind the converter – opening pressure	4,3 bar M14x1,5	
53	= Clutch Forward	16 +2 bar KV M10x1	B
55	= Clutch Reverse	16 +2 bar KR M10x1	E
56	= Clutch	16 +2 bar K1 M10x1	D
57	= Clutch	16 +2 bar K2 M10x1	A
58	= Clutch	16 +2 bar K3 M10x1	C
60	= Clutch	16 +2 bar K4 M10x1	F
63	= Behind the converter Temperature 100° C, short-time 120° C	M14x1,5	
65	= System pressure	16 +2 bar M10x1	K
Measuring points for delivery rates:			
15	= Connection to the heat exchanger	1 ⁵ / ₁₆ “ - 12 UN-2B	
16	= Connection from the heat exchanger	1 ⁵ / ₁₆ “ - 12 UN-2B	
INDUCTIVE TRANSMITTERS, SPEED SENSOR AND SWITCHES:			
21	= Inductive transmitter	n Turbine M18x1,5	
34	= Speed sensor	n Output and Speedometer -----	
47	= Inductive transmitter	n Central gear train M18x1,5	
48	= Inductive transmitter	n Engine M18x1,5	
54	= FILTER CONTAMINATION SWITCH	M14x1,5	
CONNECTIONS:			
49	= Plug connections on the electro-hydraulic control unit		
68	= System pressure	(Option) M16x1,5	G
69	= Control	(Option) M16x1,5	J
70	= Emergency steering pump	- Pressure line M22x1,5	
71	= Emergency steering pump	- Suction line M33x2	

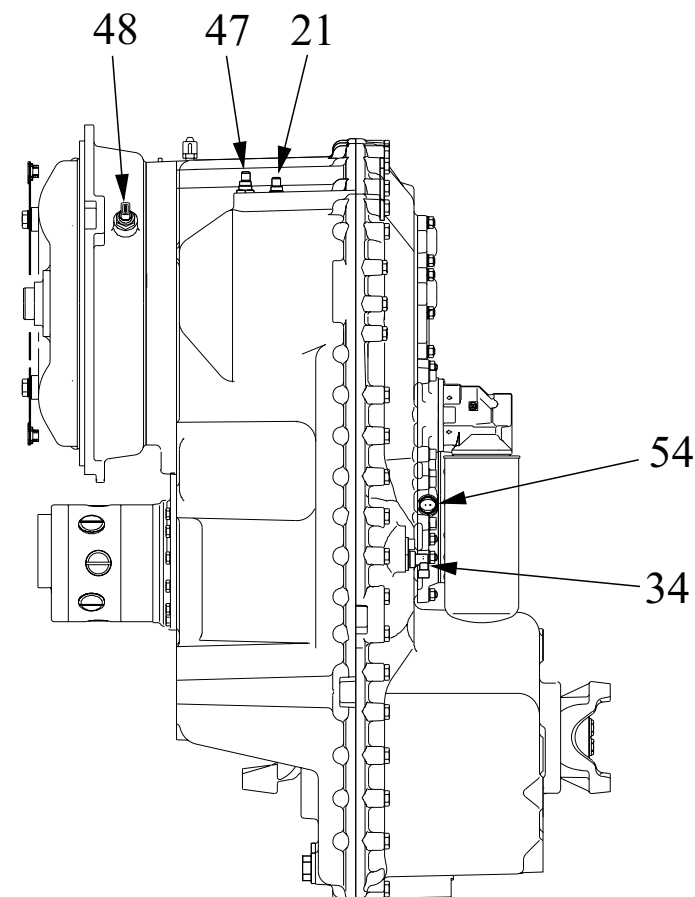

VIEW X

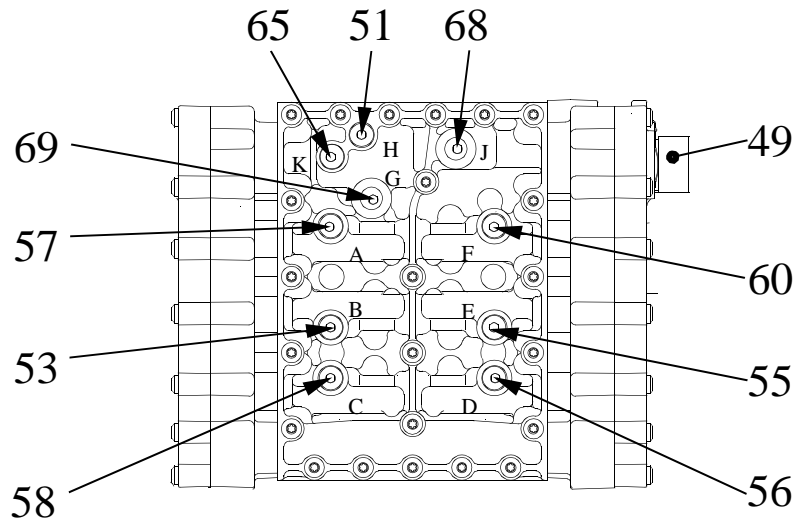

VIEW Y

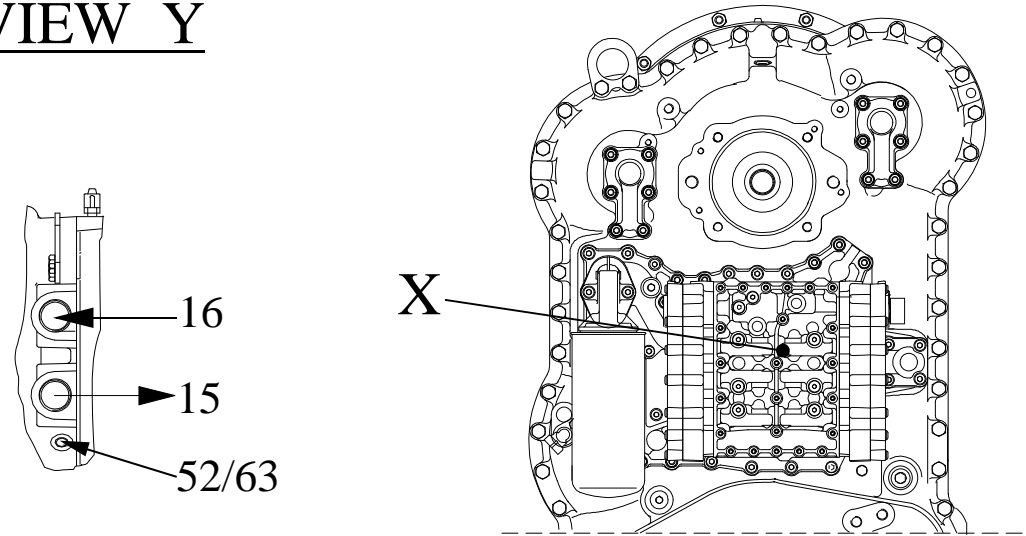

CODING

Driving direction	Speed	Pressure regulator active						Engaged clutches	
		Y1	Y2	Y3	Y4	Y5	Y6		
FORWARD	1			•		•		K1	KV
	2					•	•	KV	K2
	3				•	•		K3	KV
	4	•			•			K4	K3
REVERSE	1		•	•				KR	K1
	2		•				•	KR	K2
	3		•		•			KR	K3
NEUTRAL									
Engaged clutches		K4	KR	K1	K3	KV	K2		
Position on the valve block		F	E	D	C	B	A		
Consecutively No. of the measurement points		60	55	56	58	53	57		

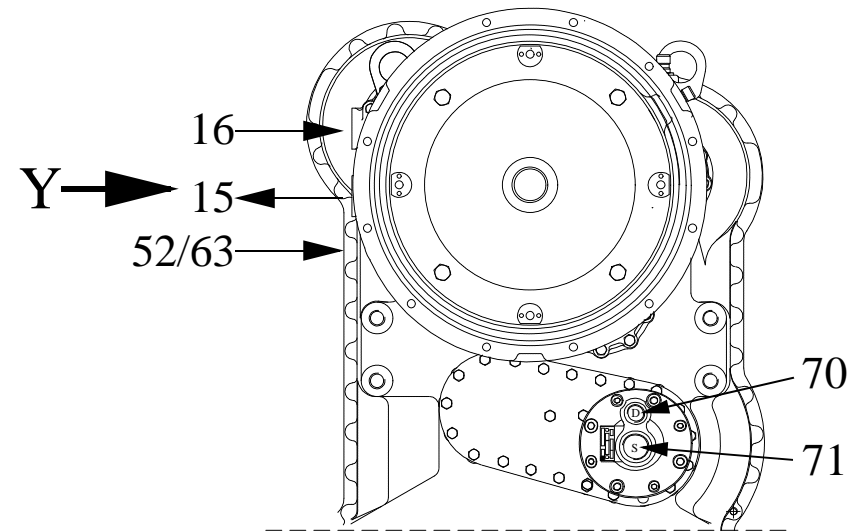

OIL CIRCUIT DIAGRAM 4 WG-190/210

FORWARD 1st SPEED

TABLE-8

The marked positons (e.g. 53) correspond with the positions on the table-7!

Legend:

WT	=	Heat exchanger	
WGV	=	Converter back pressure valve	4,3+3 bar
WSV	=	Converter safety valve	11+2 bar
HDV	=	Main pressure valve	16+2,5 bar
RV-9	=	Pressure reducing valve	9±0,5 bar
NFS	=	Follow-on slide	
D	=	Vibration damper	
B	=	Orifice	
P1	=	Proportional valve	K4
P2	=	Proportional valve	KR
P3	=	Proportional valve	K1
P4	=	Proportional valve	K3
P5	=	Proportional valve	KV
P6	=	Proportional valve	K2
Y1...Y6	=	Pressure regulators	
TEMP	=	Temperature sensor	
UEDV	=	Pressure relief valve	40±5 bar
FDV	=	Filter pressure differential valve (Bypass-valve)	$\Delta p=5,5$ bar
WS	=	Maintenance switch	

CODING

Driving direction	Speed	• Pressure regulator active						Engaged clutches	
		Y1	Y2	Y3	Y4	Y5	Y6	K1	KV
Forward	1			•		•		K1	KV
	2					•	•	KV	K2
	3				•	•		K3	KV
	4	•			•			K4	K3
Reverse	1		•	•				KR	K1
	2		•				•	KR	K2
	3		•		•			KR	K3
Neutral									
Engaged clutches		K4	KR	K1	K3	KV	K2		
Position on the valve block		F	E	D	C	B	A		
Consecutively No. of the measurement points		60	55	56	58	53	57		

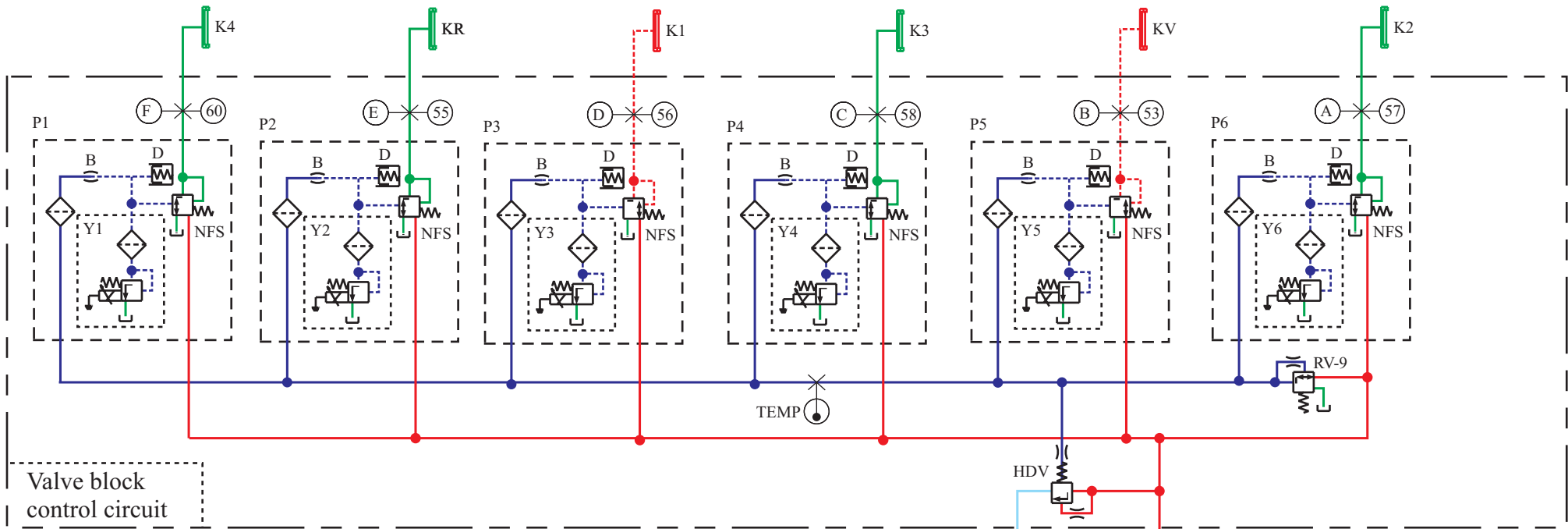

Valve block control circuit

Legend:

- = Main pressure
- - - = Regulated main pressure
- = Pilot pressure
- - - = Pilot pressure
- = Converter input pressure
- - - = Converter output pressure
- = Lubrication modulated
- = Return into the sump

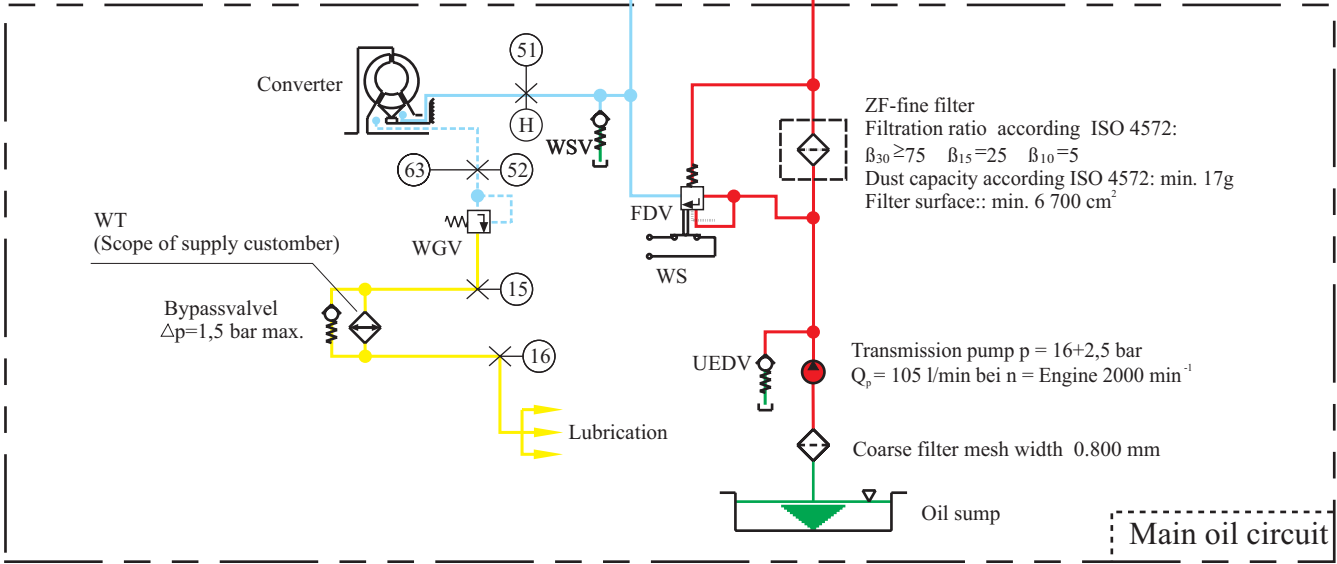

Main oil circuit

ELECTRO-HYDRAULIC CONTROL WITH PROPORTIONAL VALVES

TABLE - 9

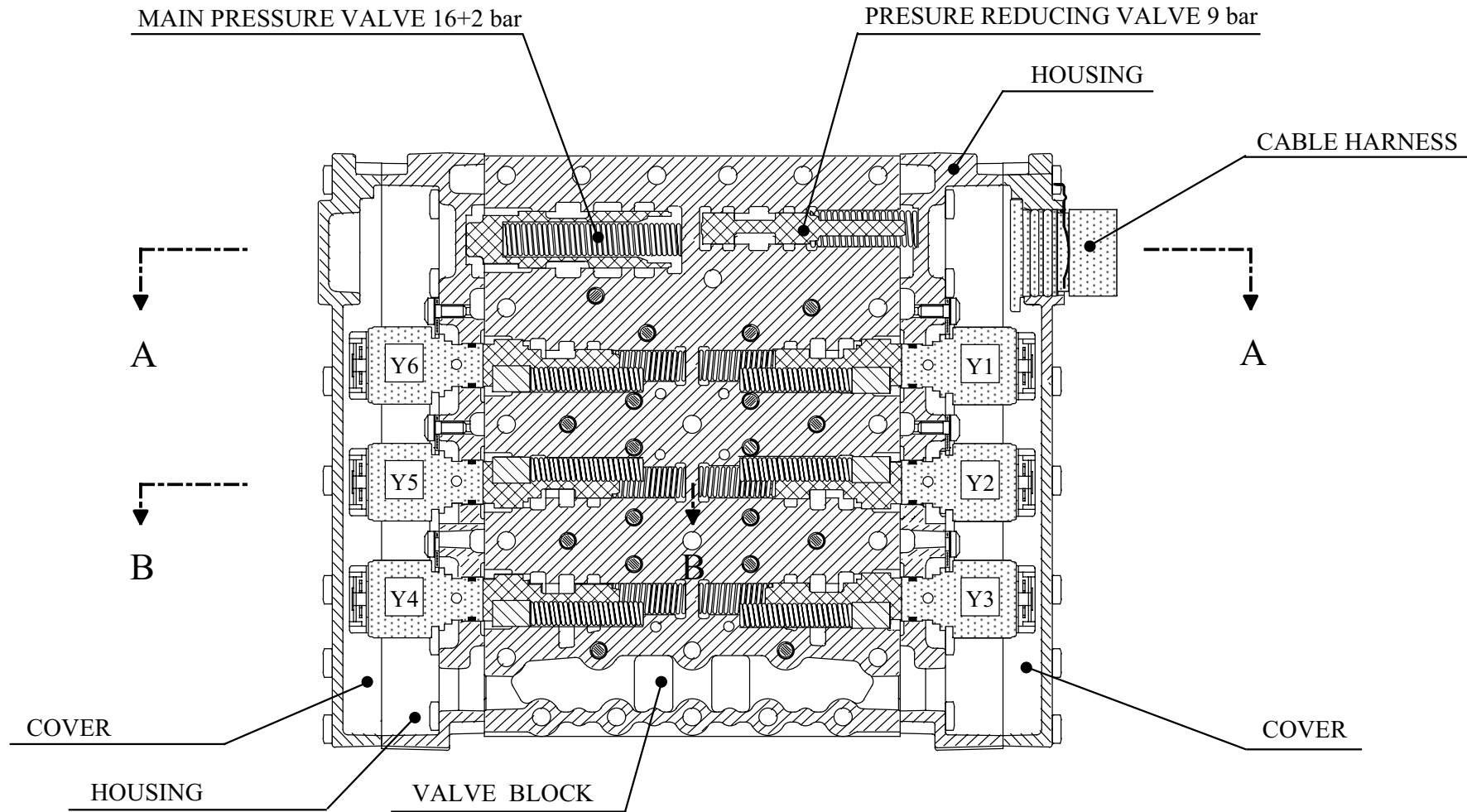

SECTION A - A

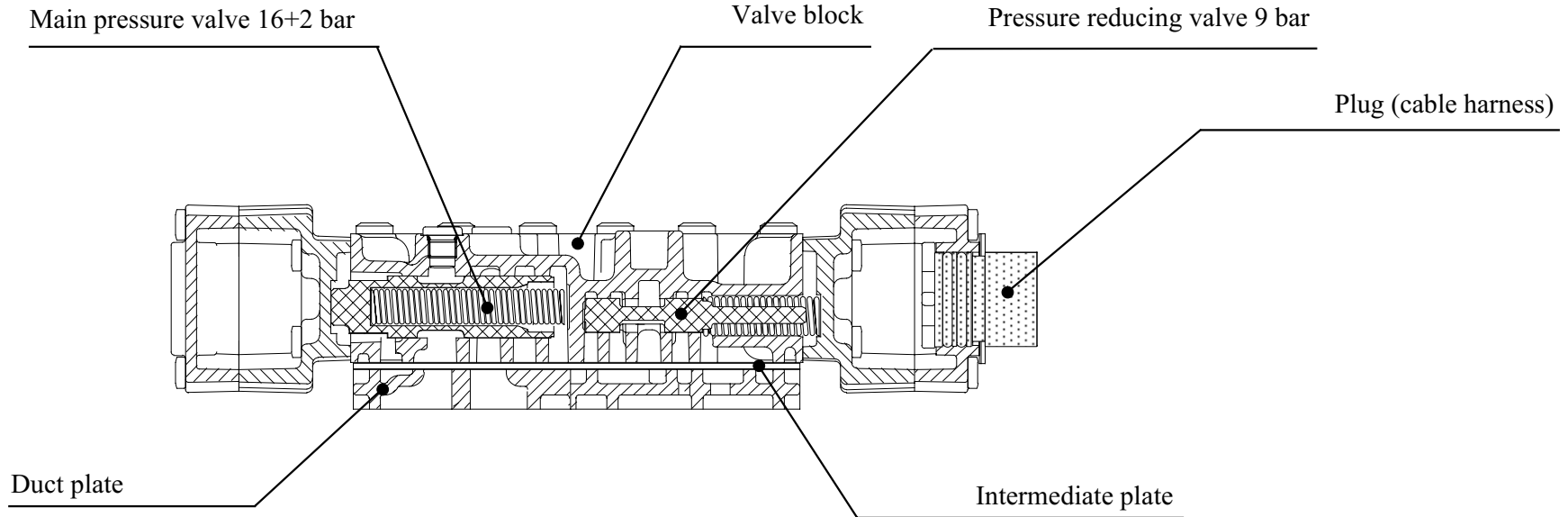

SECTION B - B

Proportional valve P5

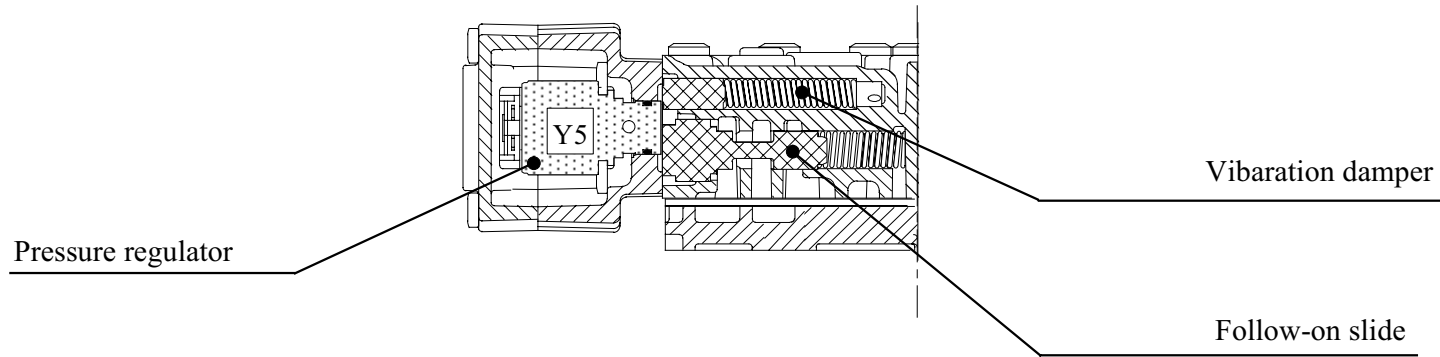

POWER FLOW 4 WG-190/210 -FORWARD/REVERSE SPEEDS

TABLE-10

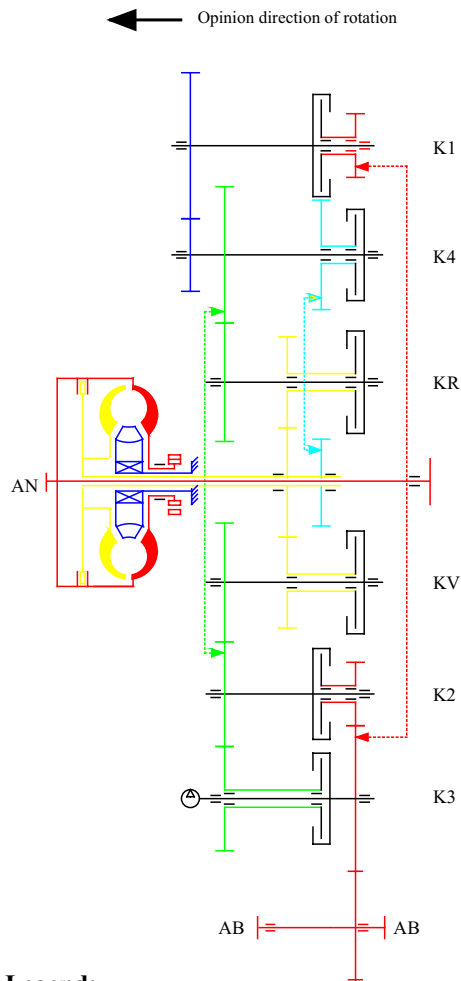

Legend:

- KV = Clutch forward
- KR = Clutch reverse
- K1 = Clutch 1st speed
- K2 = Clutch 2nd speed
- K3 = Clutch 3rd speed
- K4 = Clutch 4th speed
- AN = Input
- AB = Output

Diagram Clutches

Driving direction	Speed	Clutch
Forward	1	KV/K1
	2	KV/K2
	3	KV/K3
	4	K4/K3
Reverse	1	KR/K1
	2	KR/K2
	3	KR/K3

Legend:

- = Power flow gear train
- - - = Gears not meshing

1st speed-forward

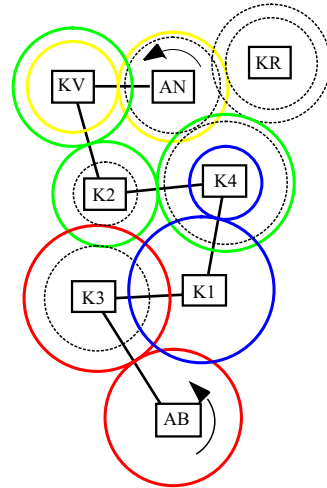

2nd speed-forward

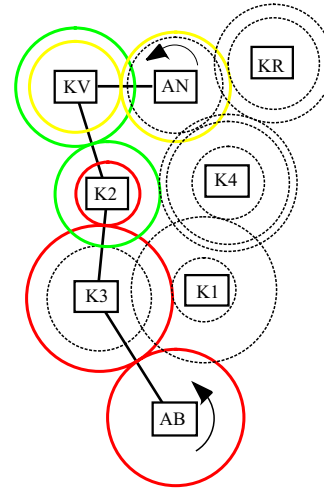

3rd speed-forward

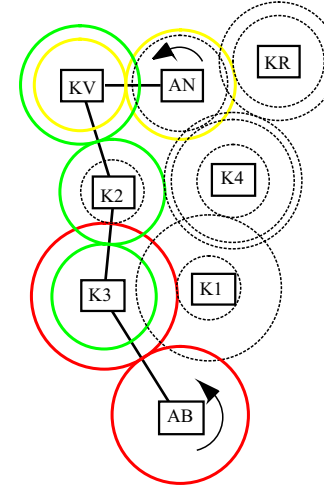

4th speed-forward

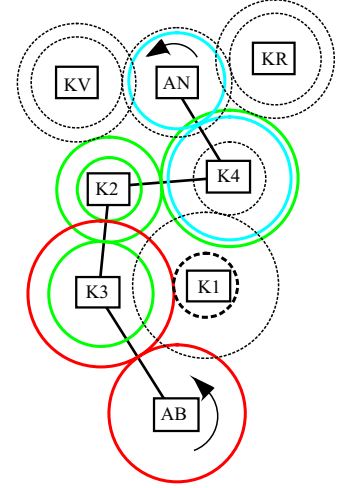

1st speed-reverse

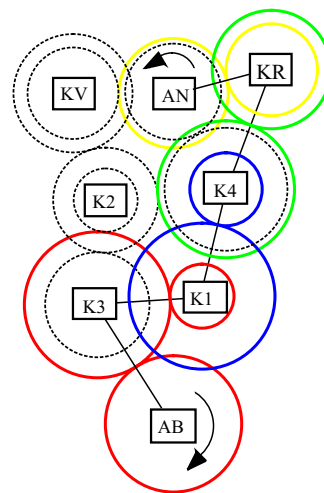

2nd speed-reverse

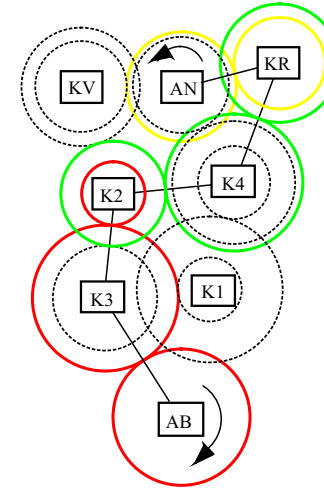

3rd speed-reverse

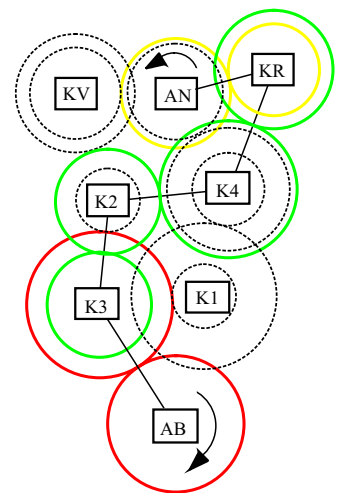

4 WG-190/210 FULLY-AUTOMATIC CONTROL EST-37 CIRCUIT DIAGRAM STANDARD (6029 717 040)

TABLE-11

ITEM	LEGEND	ITEM	LEGEND
A1	ELECTRONIC CONTROL UNIT TCU	S2	SWITCH PRESSURE CUT-OFF
A2	CONTROLLER DW-3	S3	SWITCH DRIVING PROGRAM AUTOMATIC/MANUAL
A3	ELECTRO HYDRAULIC CONTROL UNIT 4 WG-1190/210	S9	SWITCH PARKING BRAKE RELEASE (OPTION)
A5	DIAGNOSIS – INTERFACE (PLUG)	S10	SWITCH FILTER CONTAMINATION
A6	DISPLAY	S31	SWITCH ACHNOWLEDGMENT PARKING BRAKE
A7	CAN-INTERFACE (PLUG)	S34	SWITCH DISPLAY ILLUMINATION *
		K1	RELAIIY STARTER INTERLOCK *
B1	SPEED SENSOR n ENGINE	K2	RELAIIY REVERSE DRIVE *
B2	SPEED SENSOR n TURBINE		
B3	SPEED SENSOR n CENTRAL GEAR TRAIN		
B4	SPEED SENSOR n OUTPUT		
B15	SENSOR TEMPERATURE BEHIND CONVERTER		
F1	FUSE 7,5 A*		
F2	FUSE 7,5 A*		
H3	ACOUSTIC - / OPTICAL WARNING *		

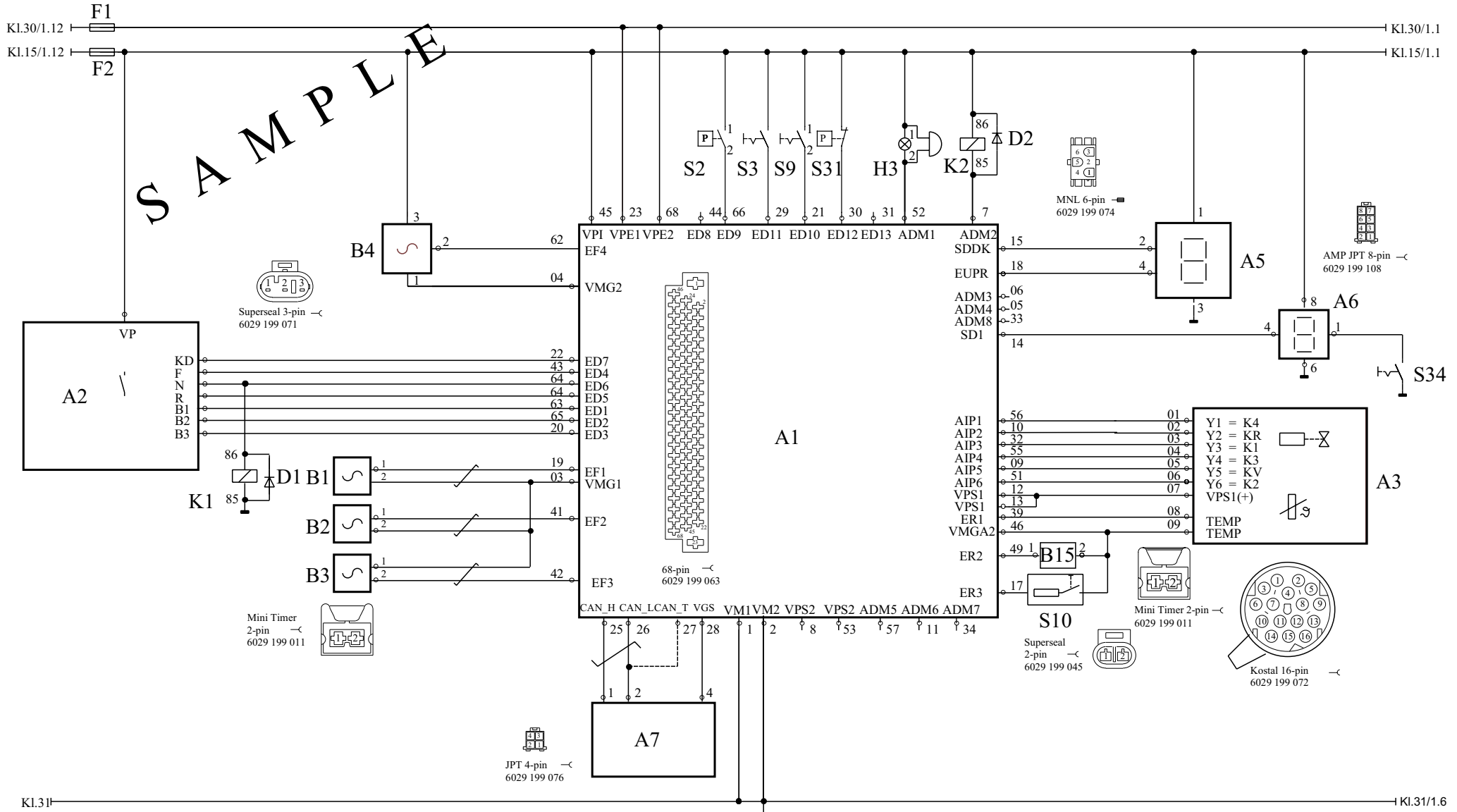

 TWISTED LINES (30 WINDINGS/METER) FROM A LENGTH OF > 2 METERS ON

BUS TERMINATION IF PIN 26 AND 27 ARE CONNECTED

Pole patterns are corresponding with the plugs on the wiring!
ALL RELAYS WITH PROTECTIVE DIODES 1A/400V

CONTROLLER DW-3

TABLE-12

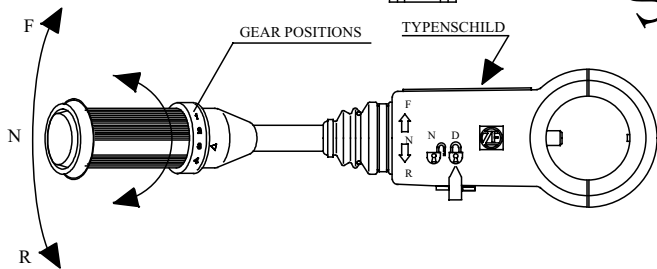
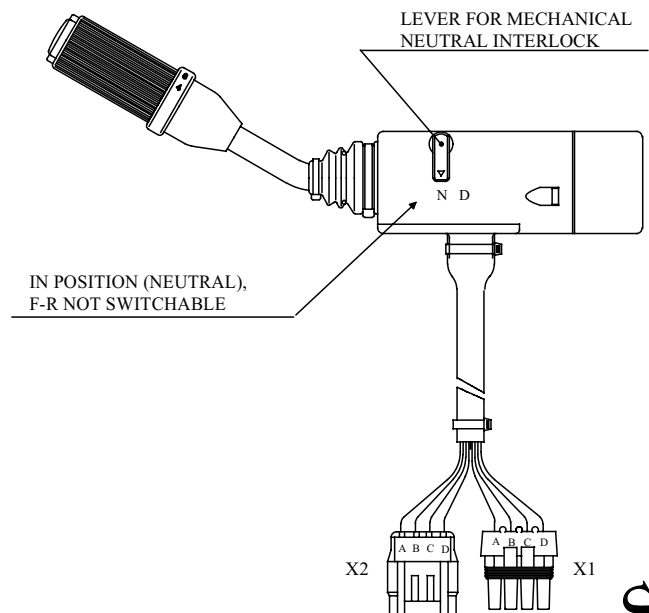

- F = FORWARD
- N = NEUTRAL
- R = REVERSE
- D = MECHANICAL NEUTRAL INTERLOCK
- 1 = 1st SPEED
- 2 = 2nd SPEED
- 3 = 3rd SPEED
- 4 = 4th SPEED

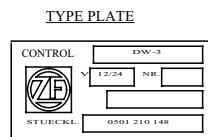

CODING CONTROLLER

		OUTPUT												KD			
SPEED		FORWARD				REVERSE				NEUTRAL							
		1	2	3	4	1	2	3	4	1	2	3	4				
AD1	B1	•				•	•			•	•			•	•		
AD2	B2			•	•			•	•			•	•			•	•
AD3	B3	•	•	•	•	•	•	•	•	•	•	•	•	•	•	•	•
AD4	V	•	•	•	•												
AD5	R					•	•	•	•								
AD6	AS													•	•	•	•
AD7																	•

SAMPLE

CONNECTION DIAGRAM CONTROLLER

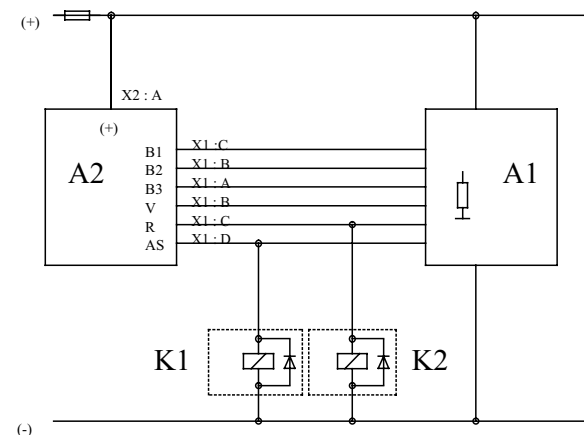

- K1 = RELAY STARTER INTERLOCK
- K2 = RELAY REVERSING LIGHTS
- A1 = ELECTRONIC UNIT EST-37
- A2 = CONTROLLER

CIRCUIT DIAGRAM CONTROLLER

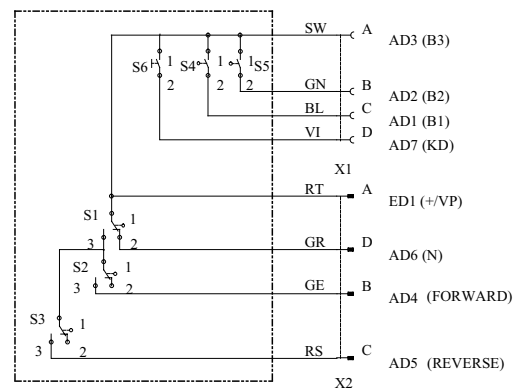

CONTROLLER ERGO II

TABLE-13

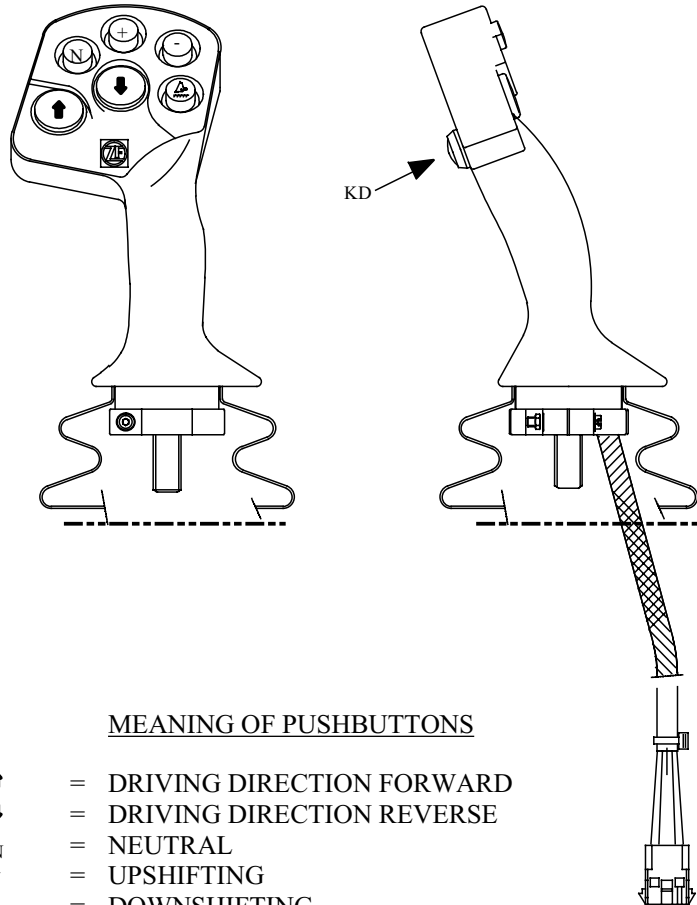

MEANING OF PUSHBUTTONS

- ↑ = DRIVING DIRECTION FORWARD
- ↓ = DRIVING DIRECTION REVERSE
- N = NEUTRAL
- + = UPSHIFTING
- = DOWNSHIFTING
- ⚙️ (SN) = SHOVEL-NEUTRAL (SHOVEL HORIZONTAL)
- KD/E = KICKDOWN CONTROL AND SAFETY RELEASE

CODING CONTROLLER

		OUTPUT						
		V	R	N	T+	T-	KD/E	SN
AD1	B1				●			
AD2	B2					●		
AD3	B3	○	●					
AD5	V	○						
AD6	R		○					
AD7	N			○				
AD8	KD						●	
AD9	SN							●

- := U OUTPUT = 0V (ACTIVE LOW)
- := U SERVICE - 0,3 V

CONNECTION DIAGRAM CONTROLLER

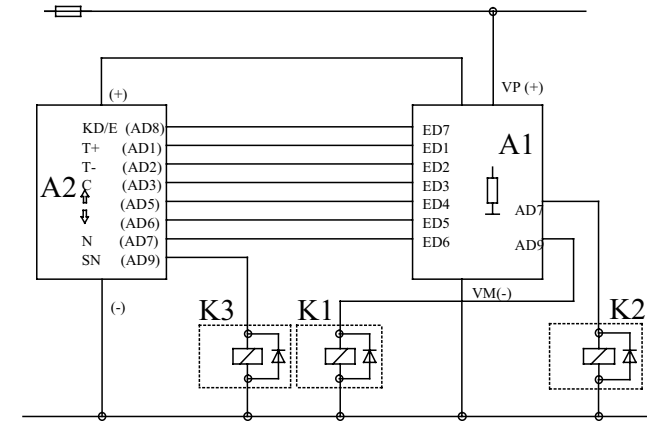

- K1 = RELAY STARTER INTERLOCK
- K2 = RELAY REVERSING LIGHTS
- K3 = RELAY SHOVEL NEUTRAL (CUSTOMIZED)
- A1 = ELECTRONIC UNIT EST-17T/EST-25
- A2 = CONTROLLER ERGO II

CIRCUIT DIAGRAM CONTROLLER

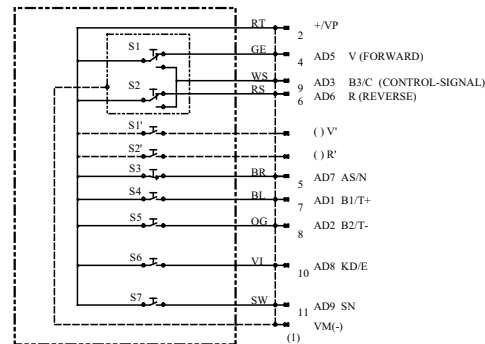

POS	LEGEND
S1	PUSHBUTTON DRIVING DIRECTION FORWARD AND C-SIGNAL FORWARD
S2	PUSHBUTTON DRIVING DIRECTION REVERSE AND C-SIGNAL REVERSE
S3	PUSHBUTTON NEUTRAL
S4	PUSHBUTTON UPSHIFTING
S5	PUSHBUTTON DOWNSHIFTING
S6	PUSHBUTTON KICKDOWN/RELEASE
S7	PUSHBUTTON SHOVELNEUTRAL

**INSCRIPTIONS ON A ZF-MODEL IDENTIFICATION
PLATE FOR ZF-HYDROMEDIA-REVERSING -TRANSMISSION**

- 1 = Gearbox type
- 2 = Gearbox-No.
- 3 = ZF-Parts List-No.
- 4 = Total ratio of the Gearbox
- 5 = Value for the control pressure
- 6 = ZF-Parts List-No. of the Torque Converter
- 7 = Type of the ZF-Torque Converter

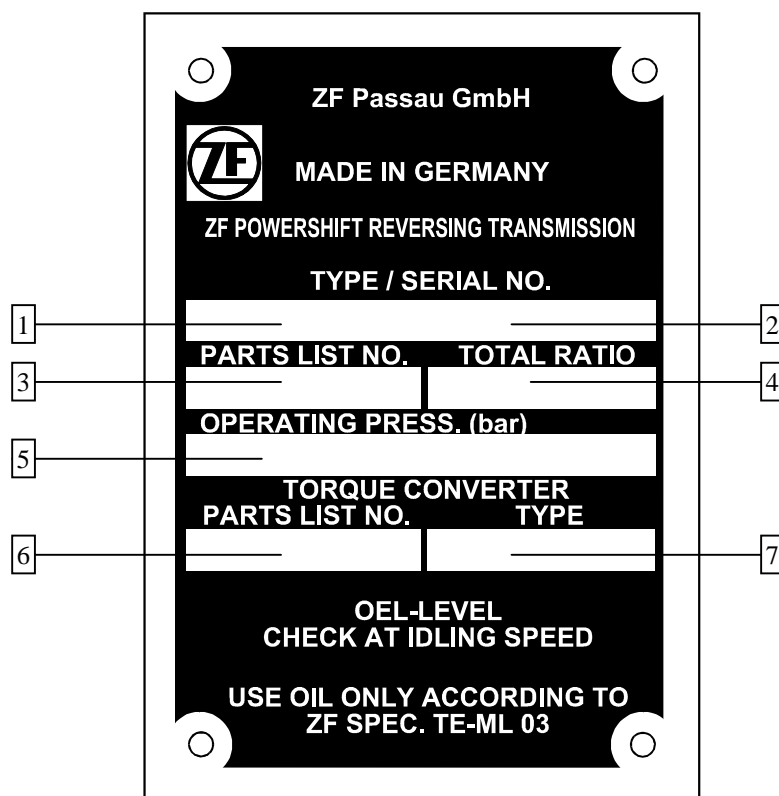

NOTES REGARDING THE SPARE PARTS ORDERS:

When ordering genuine ZF-Spare Parts, please indicate:

- 1. = Gearbox type
- 2. = Serial-No.
- 3. = ZF-Parts List-No.
- 4. = Mark and type of vehicle
- 5. = Denomination of the spare part
- 6. = Spare parts-No.
- 7. = Way of transport

} **See Model identification Plate!**

When all of the above required indications are considered, errors in the delivery of spare parts Orders can be avoided!